

# OPERATING INSTRUCTIONS

**DINO 135T • 150T • 180T**

**Manufacturer:**

**Dinolift Oy**

Raikkolantie 145

FI-32210 LOIMAA

Tel. +358 20 1772 400

[info@dinolift.com](mailto:info@dinolift.com)

[www.dinolift.com](http://www.dinolift.com)

**Dealer:**

---

---

**TRANSLATION OF THE ORIGINAL INSTRUCTIONS****Valid from serial number**

<b>135T</b>	<b>13453 --&gt;</b>
<b>150T</b>	<b>2077 --&gt;</b>
<b>180T</b>	<b>5000 --&gt;</b>

## CONTENTS

<b>1.</b>	<b>TO THE OPERATOR</b> .....	<b>7</b>
1.1.	OVERVIEW OF THE UNIT.....	8
1.2.	INTENDED USE OF THE WORK PLATFORM.....	8
<b>2.</b>	<b>TECHNICAL SPECIFICATIONS</b> .....	<b>9</b>
2.1.	DIMENSION DRAWINGS.....	10
2.1.1.	135T.....	10
2.1.2.	150T.....	11
2.1.3.	180T.....	12
2.2.	REACH DIAGRAM.....	13
2.2.1.	135T.....	13
2.2.2.	150T.....	14
2.2.3.	180T.....	15
2.3.	EXAMPLE OF THE MACHINE'S NAMEPLATE.....	16
2.4.	EXAMPLE OF EU DECLARATION OF CONFORMITY.....	17
2.5.	SAMPLE OF INSPECTION PROTOCOL FOR THE ACCESS PLATFORM.....	18
<b>3.</b>	<b>SAFETY</b> .....	<b>20</b>
3.1.	SAFETY INSTRUCTIONS.....	20
3.2.	SAFETY-RELATED NOTIFICATIONS.....	24
3.3.	SAFETY DEVICES.....	25
<b>4.</b>	<b>STRUCTURE AND FUNCTIONS OF THE WORK PLATFORM</b> .....	<b>30</b>
4.1.	STRUCTURE OF THE WORK PLATFORM.....	30
4.2.	FUNCTIONS OF THE WORK PLATFORM.....	31
4.3.	OPERATING CONTROLS FOR THE FUNCTIONS.....	32
4.3.1.	Operating controls in the chassis control centre.....	32
4.3.2.	Operating controls for the driving device.....	33
4.3.3.	Operating controls for the outriggers.....	33
4.3.4.	Operating controls in platform control centre UCB.....	34
4.3.5.	Setup with two control levers (option).....	36
<b>5.</b>	<b>OPERATING INSTRUCTIONS</b> .....	<b>37</b>
5.1.	START-UP.....	37
5.1.1.	Worksite inspection.....	37
5.1.2.	Positioning the lift.....	38
5.1.3.	Connecting the power supply to the lift.....	39
5.1.4.	Starting up.....	40
5.1.5.	Supporting the lift.....	40
5.2.	OPERATION.....	41
5.2.1.	Operating the lift from the chassis control centre.....	41
5.2.2.	Operating the lift from the platform control centre.....	41
5.2.3.	Special instructions for winter use.....	44
5.2.4.	Ending the work.....	44

5.3.	TRANSFERRING THE LIFT.....	45
5.3.1.	Preparing the lift for transport .....	45
5.3.2.	Using the driving device.....	46
5.3.3.	Towing the lift .....	48
5.3.4.	Lifting the device .....	49
5.4.	LONG-TERM STORAGE .....	50
5.5.	IN CASE OF EMERGENCY .....	52
5.5.1.	When at risk of losing the stability .....	52
5.5.2.	In case of overloading.....	52
5.5.3.	In case of power failure.....	52
5.5.4.	In case of malfunction, when even the emergency descent system is not operational	53
<b>6.</b>	<b>INSTRUCTIONS FOR FAULT-FINDING .....</b>	<b>54</b>
<b>7.</b>	<b>MAINTENANCE SCHEDULE.....</b>	<b>58</b>
7.1.	SCHEDULE FOR INSPECTIONS REQUIRED BY THE AUTHORITIES .....	60
7.2.	LUBRICATION PLAN .....	61
<b>8.</b>	<b>ROUTINE MAINTENANCE DURING OPERATION .....</b>	<b>62</b>
8.1.	INSTRUCTIONS FOR DAILY MAINTENANCE AND INSPECTIONS .....	63
8.1.1.	Check the condition of chassis, the boom and the work platform.....	63
8.1.2.	Check the tyres and tyre pressure.....	63
8.1.3.	Check the lights .....	63
8.1.4.	Check the hydraulic oil level .....	63
8.1.5.	Check the hydraulic hoses, pipes and connectors .....	63
8.1.6.	Check the operation of the safety limit switches.....	64
8.1.7.	Check the operation of the emergency descent, the emergency stop and the sound signal	64
8.1.8.	Decals, stickers and signs .....	64
8.1.9.	Instruction manuals.....	64
<b>9.</b>	<b>CHANGE OF OWNER.....</b>	<b>67</b>



**BLANK**



## 1. TO THE OPERATOR

Keep this manual on the work platform of the lift in the box reserved for it. If the instruction manual gets lost, damaged, or for some other reason becomes unreadable, order a new manual from the manufacturer.

This manual is intended to familiarise the user with the structure and functions of the work platform, as well as with its appropriate use. The manual provides guidance on the service measures that are the responsibility of the user of the work platform.

Other maintenance procedures on the work platform require special skills, special tools or accurate knowledge about measurements or adjusted values. Guidance for these measures is provided in a separate service manual. For situations that require service or repair measures, contact the authorised service provider, importer or manufacturer.



### **DANGER**

Read all the instructions in this manual before using the aerial work platform. Make sure that you have understood all the instructions. The instructions must absolutely be followed during operation and maintenance of the aerial work platform.

When handling the unit, in addition to the instructions in this manual, the user must also observe the local legislation, the guidelines stipulated by the employer, and regulations valid at the work site.

Dinolift Oy is constantly developing its products. For this reason, the contents of this manual might not always be in full compliance with the most recent version of the product. Dinolift Oy reserves the right to modify the product without prior notice. Dinolift Oy assumes no liability for any problems caused by changed or missing data or mistakes in this manual.

Please consult your dealer or the manufacturer for more information and detailed instructions.

## 1.1. OVERVIEW OF THE UNIT

This unit is a trailer mounted, towable aerial work platform.

It is an aerial work platform, which complies with the EN280 type 1, where travelling is only allowed with the platform in transport configuration.

For the operation the lift shall be supported by its hydraulic outriggers, extended so that the wheels of the trailer lift off the ground.

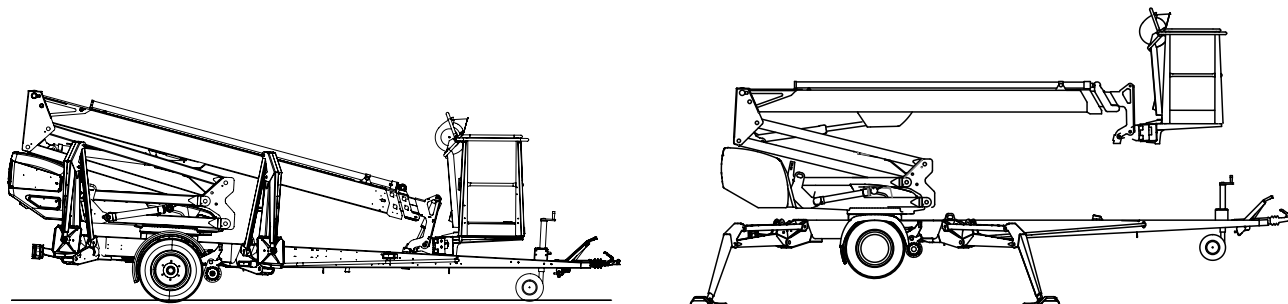

Nostimen ensisijaisena voimanlähteenä on sähkömoottorikäyttö. The outriggers and the boom system are hydraulically powered.

As an option, the lifts can be equipped with a driving device that can be controlled from the ground.

Consult the chapters “Technical data” and “Structure and functions of the work platform” in this manual for more detailed information about the lift.

## 1.2. INTENDED USE OF THE WORK PLATFORM

The aerial work platform is exclusively intended for transferring people and tools and acting as a work platform within its permissible load-bearing capacity and reach (refer to the “Technical Specifications” table and the “Reach Diagram”).

The intended use also covers:

- Following all the instructions in the Operating Instructions
- Performance of the inspections and maintenance operations.

This aerial work platform is NOT insulated, and does not offer protection against contact with electric current. The aerial work platform must not be used for work on electric systems.

Observe the safety instructions concerning the operating environment, and the restrictions given in them,

### **NOTICE**

**The operator must receive instructions and consent from the manufacturer for all such specific work methods or conditions that the manufacturer has not explicitly defined in the unit's operation and maintenance instructions.**



## 2. TECHNICAL SPECIFICATIONS

	135T	150T	180T
Max. working height	13,5 m	15,0 m	18,0 m
Max. platform height	11,5 m	13,0 m	16,0 m
Max. outreach	9,1 m	10,0 m	10,7 m
Boom rotation	continuous		
Platform rotation	90°		
Turn area	refer to the reach diagram		
Support width	3,8 / 4,2 m	3,8 / 4,2 m	3,8 / 4,2 m
Transport width	1,78 m	1,78 m	1,78 m
Transport length	5,96 m	6,53 m	7,46 m
Transport height	2,16 m	2,24 m	2,19 m
Weight (incl. Honda power unit)	1635 kg	1675 kg	1840 kg
Max. allowed load on platform	215 kg		
Max. number of persons + additional load	2 persons + 55 kg		
Max. allowed sideways load (caused by persons)	400 N		
Max. lateral inclination (chassis)	±0,3°		
Max. allowed gradient of ground to the side	2,4°	2,4°	2,4°
Max. allowed gradient of ground lengthwise	4,0°	3,8°	3,8°
Max. wind speed during operation	12,5 m/s		
Min. ambient temperature when working	- 20 °C		
Max. support force on the outriggers	11300 N	12800 N	16800 N
Platform size	0,7 x 1,3 m		
Gradeability	25%		
Socket outlets on the platform	2 x 230V/50Hz/16A		
Power supply			
- mains current	230V/50Hz/10A		
Sound pressure level	< 70 dB		
Whole-body vibration	Not detectable		

### Optional engines

Honda GX200SXE	
Fuel	Petrol
Net power	4.1 kW (5,5 hp)
Fuel tank volume	3,1 l
Oil volume	0,6 l
Fuel consumption	1,7 l/h
Sound pressure level	98 dB
Whole-body vibration	< 0,5 m/s <sup>2</sup>



## 2.1.2. 150T

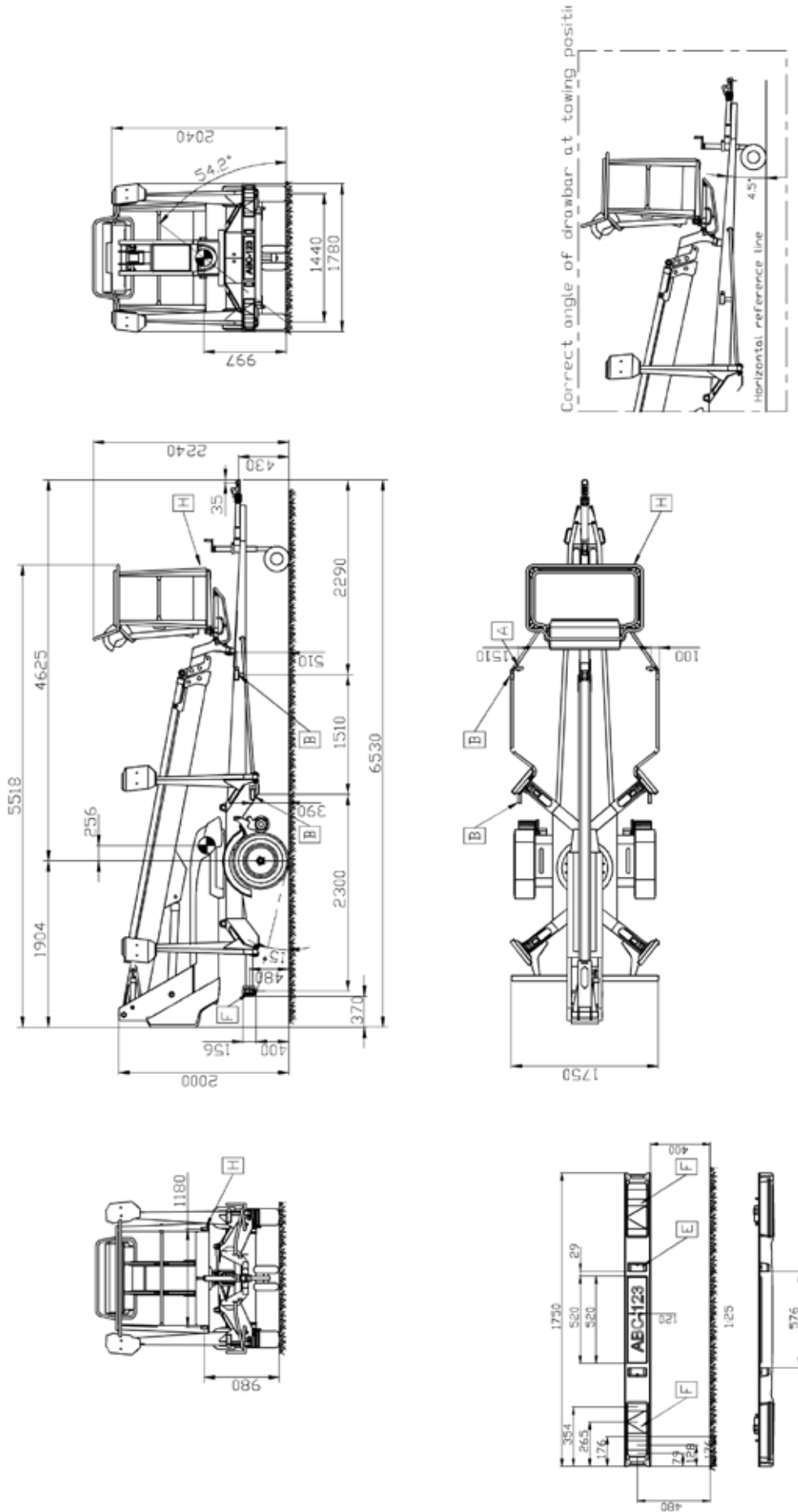

2.1.3. 180T

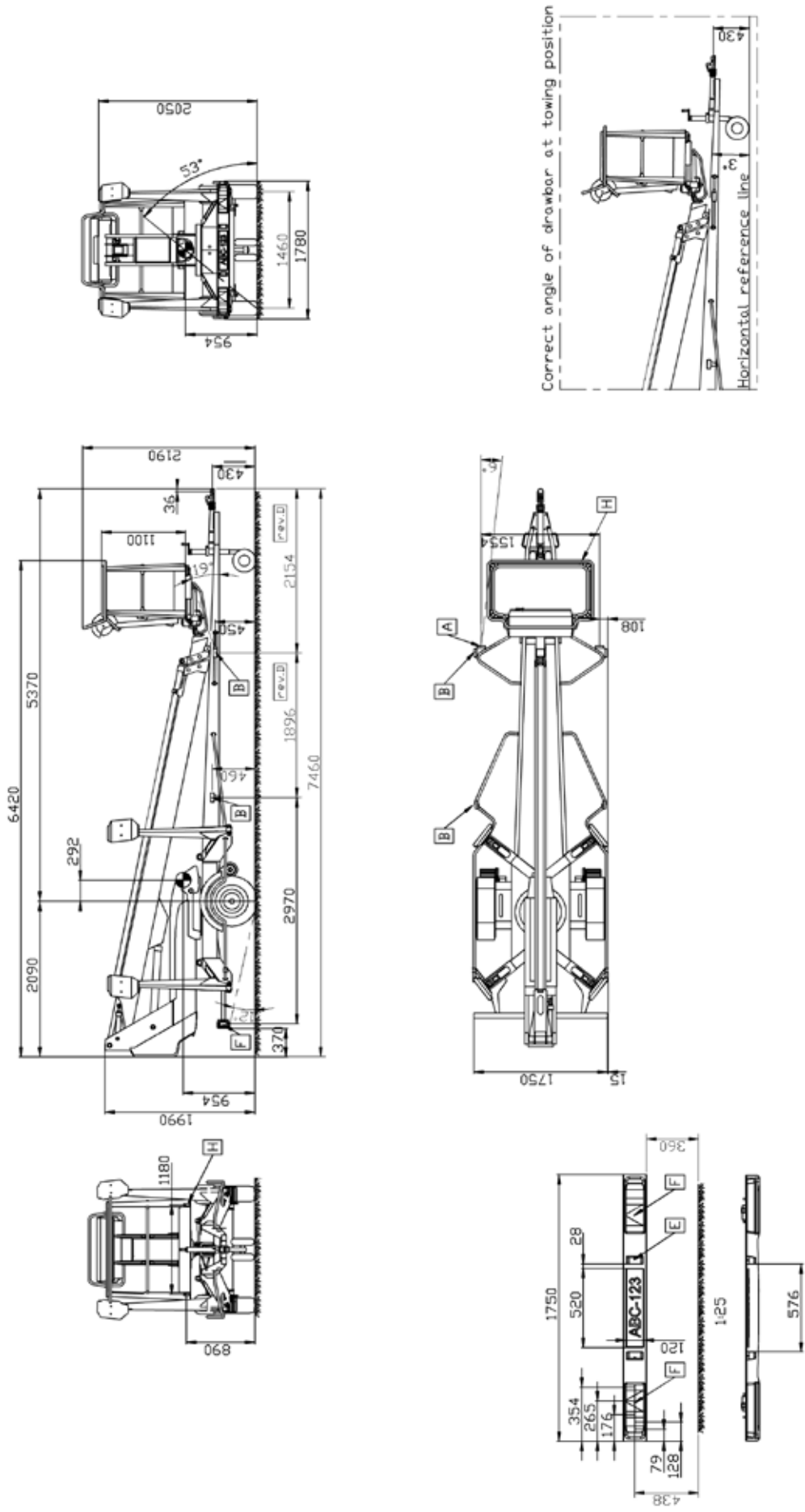

## 2.2. REACH DIAGRAM

### 2.2.1. 135T

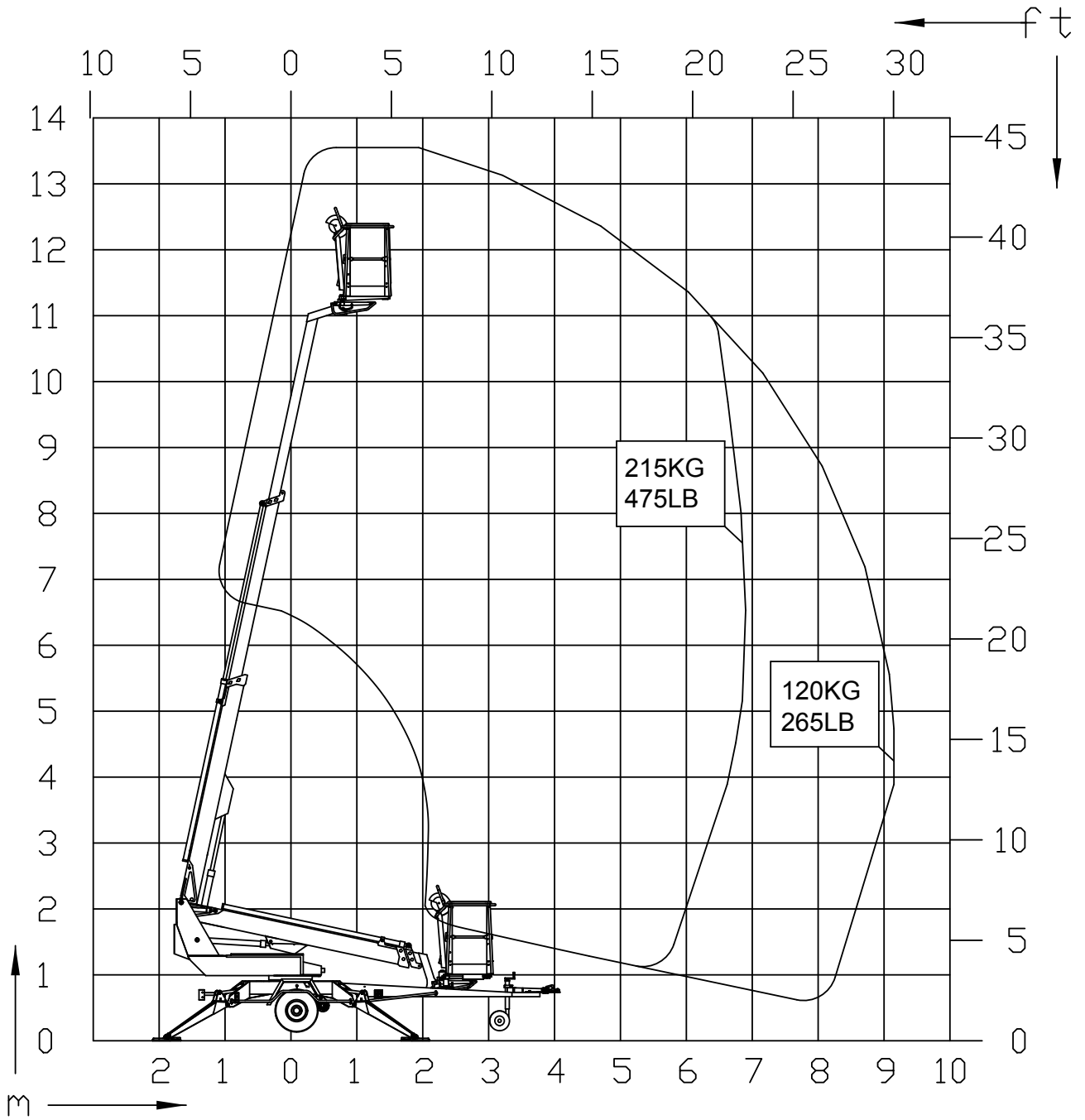

2.2.2. 150T

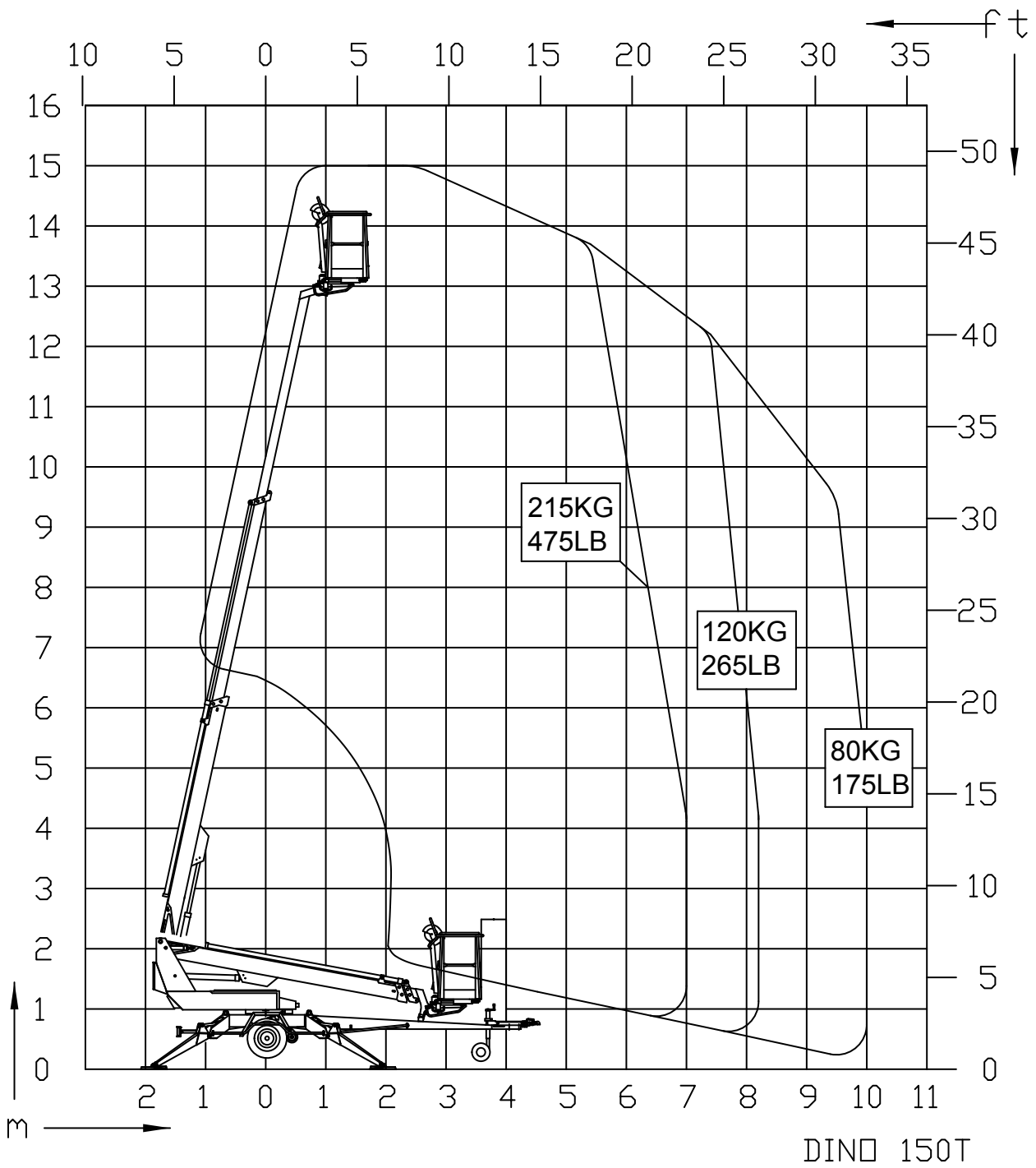

## 2.2.3. 180T

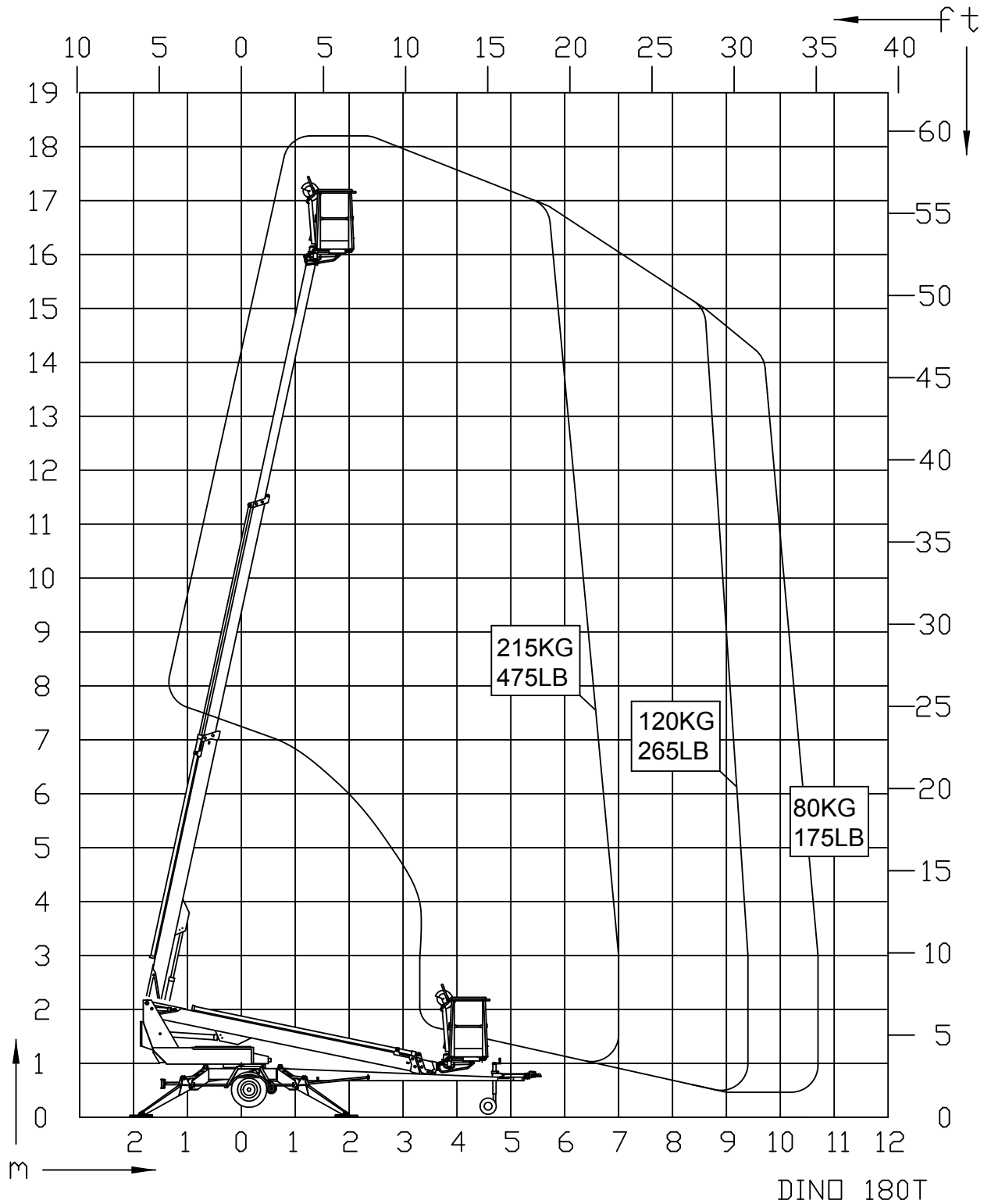

### 2.3. EXAMPLE OF THE MACHINE'S NAMEPLATE

The name of the manufacturer, and the production number and serial number of the machine have been marked on the nameplate as shown in the picture below.

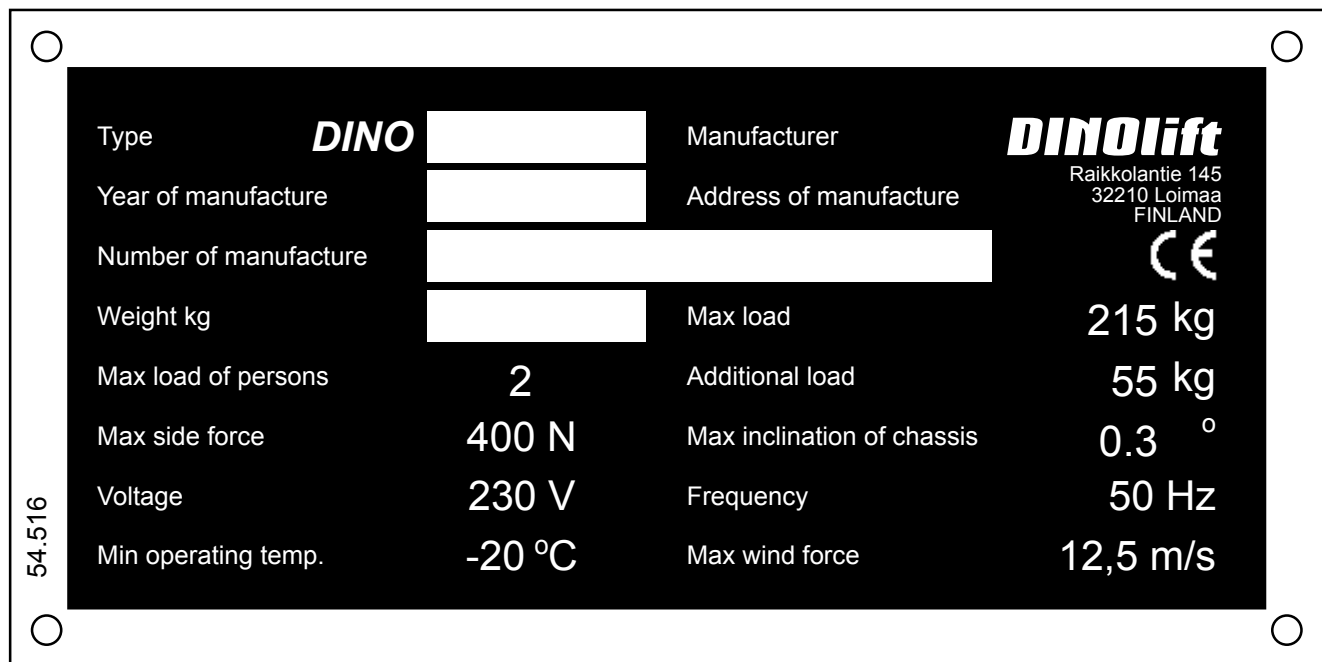

The nameplate of the lift is located on the right-hand side of the tow-bar, as shown in the picture.



The serial number is also engraved in the lift's chassis, on the upper surface of the right-hand tow-bar.

The nameplate of the trailer is located on the tow-bar, on the right-hand side of the nameplate of the lift, as shown in the picture.



Following data is written on the plate:

	EU Type Approval Number (if available)	
	Serial number	
	Total weight	kg
0	Maximum allowed weight on the towing hitch	kg
1	Maximum allowed axle weight	kg
2		kg



**2.4. EXAMPLE OF EU DECLARATION OF CONFORMITY****EU declaration of conformity for machine****Manufacturer**

Dinolift Oy  
Raikkolantie 145  
FI-32210 Loimaa, FINLAND

declares that

**DINO 135T Aerial Work Platform no YGC0D135TF0013562**

conforms to the provisions of the Machine Directive **2006/42/EC** as well as the national decree (**VNA 400/2008**), through which they have been brought into effect

The inspection in accordance with Annex IX to the directive 2006/42/EC has been carried out by the notified body no. 0537,

VTT  
P.O.Box 1300  
FI-33101 Tampere, FINLAND

has granted the certificate no. **VTT 174/524/14**

In addition, the aerial work platform also complies with the provisions of the following European Directives:

**2006/95/EC, 2000/14/EC, 2004/108/EC**

Measured sound power level  $L_{wa}$  ( 99 + 1,5 ) 100,5 dB  
Guaranteed sound power level  $L_{wa}$  100,5 + 0,5 dB

To the assessment procedure of conformity has been applied: 2000/14/EC, Annex V: Internal control of production.

In designing the machine, the following harmonised standards have been applied:

**SFS-EN 280:2013, SFS-EN 60204-1/A1, SFS-EN-ISO 12100**

The person, who has compiled the technical construction file: Santtu Siivola

Chief Engineer  
Dinolift Oy, Raikkolantie 145,  
FI-32210 Loimaa, FINLAND

Loimaa 11.05.2015

-----  
Tuomo Nykänen  
Production director

2.5. SAMPLE OF INSPECTION PROTOCOL FOR THE ACCESS PLATFORM



TEST CERTIFICATE

DATE: 7.1.2015

www.dinolift.com

START-UP TESTS:

Inspection place: Dinolift Oy Inspector's signature: 1146  
 Lehtinen Sauli NT0574-2

BASIC KNOWLEDGE

Manufacturer: Dinolift Oy Place of manufacture: Finland  
 Address: Raikkolantie 145  
32210 LOIMAA  
 Importer: \_\_\_\_\_  
 Type of lift:  Boom platform  Scissor platform  Mast platform  
 Chassis:  Car  Self propelled  Trailer mounted  
 Boom:  Articulated boom  Telescope boom  Articulated telescope boom  
 Scissor  Fixed mast  Telescope mast  
 Outriggers:  Hydraulic turning  Hydraulic pushing  Mechanical

TECHNICAL SPECIFICATION

Machine and type: DINO 135 T Max. platform height: 11,5m  
 Number of manufacture: YGC0D135TF0013536 Max. outreach: depend on load: Depend on load  
 Year of manufacture: 2015  
 Max. lifting capacity: 215 kg Boom rotation: Continuous  
 Max. person number: 2 Support width: 3,8m  
 Max. additional load: 55kg Transport width: 1,78 m  
 Power supply: 230VAC Transport length: 5,94 m  
 Lowest temperature: -20 °C Transport height: 2,14 m  
 Weight: 1635 kg Basket size: 0,7x1,3 m

Inspection points: (Y = meet standards N = do not meet standards)

	Y	N		Y	N
<b>A. STRENGTH</b>					
1. Certificate of material	<input checked="" type="checkbox"/>	<input type="checkbox"/>	6. Plate for supports	<input checked="" type="checkbox"/>	<input type="checkbox"/>
2. Certificate of strength	<input checked="" type="checkbox"/>	<input type="checkbox"/>	7. Safety colours	<input checked="" type="checkbox"/>	<input type="checkbox"/>
<b>B. STABILITY</b>					
1. Certificate of stability test	<input checked="" type="checkbox"/>	<input type="checkbox"/>	<b>D. SAFETY REQUIREMENTS</b>		
2. Working space diagram	<input checked="" type="checkbox"/>	<input type="checkbox"/>	1. Indicating device for horizontal position	<input checked="" type="checkbox"/>	<input type="checkbox"/>
<b>C. GENERAL REQUIREMENTS</b>					
1. User's manual	<input checked="" type="checkbox"/>	<input type="checkbox"/>	2. Locking device and lockings	<input checked="" type="checkbox"/>	<input type="checkbox"/>
2. Place for safekeeping for user's manual	<input checked="" type="checkbox"/>	<input type="checkbox"/>	3. Stop device for lifting	<input checked="" type="checkbox"/>	<input type="checkbox"/>
3. Machine plate - checking plate	<input checked="" type="checkbox"/>	<input type="checkbox"/>	4. Stop for opening of support	<input checked="" type="checkbox"/>	<input type="checkbox"/>
4. Load plate	<input checked="" type="checkbox"/>	<input type="checkbox"/>	5. Safety distances	<input checked="" type="checkbox"/>	<input type="checkbox"/>
5. Warning plate	<input checked="" type="checkbox"/>	<input type="checkbox"/>	6. Position of working face	<input checked="" type="checkbox"/>	<input type="checkbox"/>
			7. Structure of working face	<input checked="" type="checkbox"/>	<input type="checkbox"/>
			8. Emergency descent system	<input checked="" type="checkbox"/>	<input type="checkbox"/>
			9. Limit devices	<input checked="" type="checkbox"/>	<input type="checkbox"/>

<p><b>E. ELECTRIC APPLIANCES</b></p> <p>1. Electric appliances</p>	<p><b>G. SAFETY DEVICE</b></p> <p>1. Safety limit switch</p> <p>2. Sound signal</p>
<p><b>F. CONTROL DEVICES</b></p> <p>1. Protections</p> <p>2. Symbols / directions</p> <p>3. Placings</p> <p>4. Emergency stop</p>	<p><b>H. LOADING TEST</b></p> <p>1. Overload test = 323 kg (150%)</p> <p>2. Funktional test = 237 kg (110%)</p>
<p><b>FAILINGS AND NOTES</b></p> <hr/> <hr/> <hr/>	
<p>Failings have been repaired.                      Date: _____ Signature: _____</p>	

**Dinolift Oy**  
 Raikkolantie 145  
 FIN-32210 LOIMAA, FINLAND  
 Tel. +358 - 20 - 1772 400, Fax +358 - 2 - 7627 160, e-mail: info@dinolift.com

The initial inspection and test loading of the Dino aerial work platforms is performed by the manufacturer. A protocol, drawn up during the inspection, will accompany the lift.

The protocols of the start-up and periodic inspections must be kept with the lift or its immediate proximity for at least five years.

### 3. SAFETY

All the essential safety instructions and warnings, relevant to transport, use and maintenance of the lift, are described in this chapter.



## DANGER

Failure to observe these instructions and safety regulations may cause a severe injury or even death. Familiarise yourself with all the safety regulations, operating instructions and signs affixed to the machine, and follow them.

Make sure that you understand all the safety instructions and regulations. Also make sure that others operating the machine or working on the work platform are familiar with these instructions.

#### 3.1. SAFETY INSTRUCTIONS

Only specially trained personnel with authorisation in writing, who are well familiarised with the device, and at least 18-years old, are allowed to operate the unit.

Keep the lift free of any dirt, which may impair safe operation, and impede the inspection of the structures.

The device must be serviced and inspected regularly.

Only skilled persons, familiar with the service and repair instructions, are allowed to carry out servicing and repair work.

It is strictly prohibited to use a lift which is out of order.

Never remove or disable any safety devices or covers of the machine.



## WARNING

The device must neither be altered without the manufacturer's consent nor be used under conditions, which do not meet the manufacturer's requirements.

The operator must be given instructions and consent from the manufacturer for all such specific work methods or conditions that the manufacturer has not explicitly defined.

## **TRANSFERS**

Observe the maximum allowed gradient when transferring the lift. During transfer in rough terrain, try to stay above the machine.

Beware of fixed or moving obstacles in the terrain or near the lift while driving. Make sure that you have a clear view of the driving path.

## **WORK AREA AND PREPARATIONS BEFORE LIFTING WORK**

When working in busy areas, the operating range of the lift must be clearly marked by using either warning lights or fencing.

Also observe road traffic regulations.

Ensure the unobstructed range of movement before operating the outriggers.

The load-bearing capacity and the gradient of the base must be taken into account when supporting the chassis.

Ensure that the outriggers cannot slide while on a gradient.

Additional support plates of adequate size must be used under the outriggers, when working on soft ground. Only use such additional support plates, on which the metallic outriggers will not slide.

While in the support position, ensure that the wheels are off the ground.

Always verify the horizontal position of the machine.

Always ensure that the work area is clear of outsiders. Danger of getting squeezed between rotating and fixed structures.

**While operating the boom from the control centre on the turning device, beware of getting pressed against the outriggers or other structures that do not turn with the boom.**

## LIFTING AND WORKING ON THE PLATFORM

Before operating, always ensure that the safety devices and the emergency descent system are in working order.

Never use a lift alone. Make sure that there is always someone on the ground, who can call for help in case of an emergency.

The max. allowed load on the platform is two (2) persons and at maximum fifty five (55) kg of additional load, however, the total load must not exceed two hundred fifteen (215) kg.

The lift must not be used as a crane.

### Use the safety harness!

Do not use ladders, steps or other similar equipment on the platform.

Never add load onto the platform while in the upper position.

Never throw or drop any objects from the platform.



The lift must not be used for transferring goods or persons between different floors or working levels. Stepping on or off the platform in motion is prohibited.

When the boom is in its lowest positions, make sure it cannot clash during rotation with structures that do not turn with the boom.

Always make sure, before lowering the platform, that the area under it is clear.

Avoid damaging the platform by lowering it on the ground, or bringing it in contact with any structures.

## OPERATING CONDITIONS

The weather conditions, such as wind, visibility and rain, must always be taken into account so that these will not adversely affect the safe performance of the lifting operations.



**The use of the lift is prohibited if the temperature drops under -20 °C or the wind speed exceeds 12.5 m/s**

Wind speed ( m/s)		Conditions on land
0	Calm	Smoke rises vertically
1-3	Light breeze	Smoke moves with the wind and the wind feels on exposed skin. Leaves rustle.
4-7	Gentle breeze	Leaves and small branches of trees are moving. Flag is flying. Wind lifts dust and loose pieces of paper from the ground.
8-13	Strong breeze	Small broad-leaved trees and large branches sway. Wind whistles as it hits houses or other fixed objects. Umbrella is difficult to use.
14-16	Strong	All the trees are swaying. It is difficult. to walk against the wind.

Do not take tools/material of large surface area onto the platform. The increase in wind load may jeopardize the stability of the device.

**Beware of the live aerial power lines in the area – observe the minimum safety distances:**

Voltage	Min. distance below (m)	Min. distance at the side (m)
100 – 400 V hanging spiral cable	0.5	0.5
100–400 V open-wire cable	2	2
6–45 kV	2	3
110 kV	3	5
220 kV	4	5
400 kV	5	5

### 3.2. SAFETY-RELATED NOTIFICATIONS

The following safety alert symbols and safety signal words are used in this manual.

Observe all the safety instructions that follow these symbols, in order to avoid dangerous situations and personal injuries.



This is a general safety alert symbol and it is used to alert you about a potential hazard. Observe the additional instructions given in form of text or symbols that follow this symbol.



## DANGER

Red DANGER-message warns for an imminent or potential hazardous situation which, if not avoided, may result in death or serious injury.



## WARNING

Orange WARNING -message is used in connection with potential risk factors, which if not avoided, under certain conditions, may result in death or serious injury.



## CAUTION

Yellow CAUTION -message is used to warn about a hazardous situation which, if not avoided, could result in minor or moderate injury.

## NOTICE

Blue notice-message is used to draw your attention to special notifications or instructions that are related to the operation or maintenance. Such messages include, for example, instructions that are related to reliability of the machine or aim to avoid material losses.



### 3.3. SAFETY DEVICES

#### 1. Supervision of transport position of the boom

The safety limit switch RK3 prevents the operation of the outriggers and the driving device when the boom is not resting on the transport support. The switch is located on the tow-bar at the transport support.

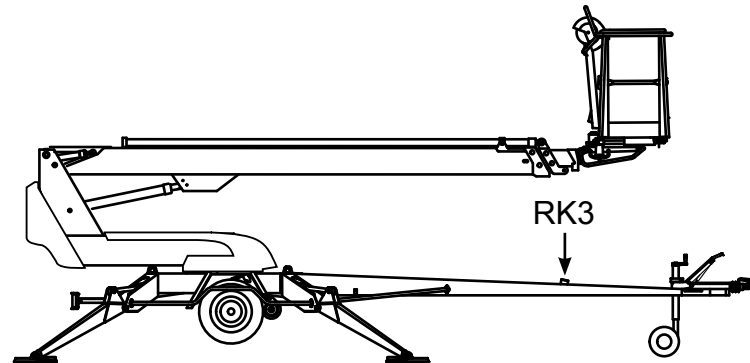

#### 2. Supervision of supporting

The lift's all support outriggers must be in the support position before the boom is lifted. Make sure that the wheels are off the ground.

The safety limit switches RK11, RK12, RK13 and RK14 are located on the support outriggers.

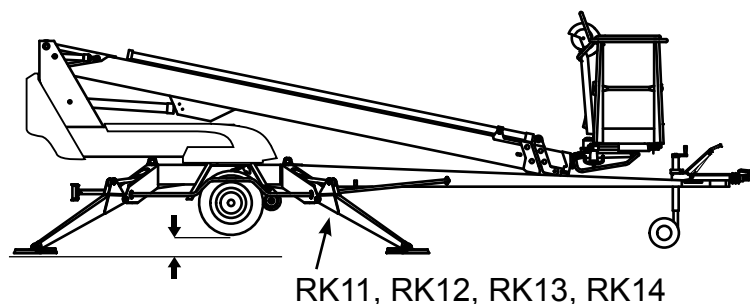

#### 3. Overload protection switches

The outreach limit switch RK4 and overload limit switch RK5 prevent the lift from being overloaded.

The limit switches are located under the cover at the top end of the lifting cylinder. During operation, the cover must be intact and in place.

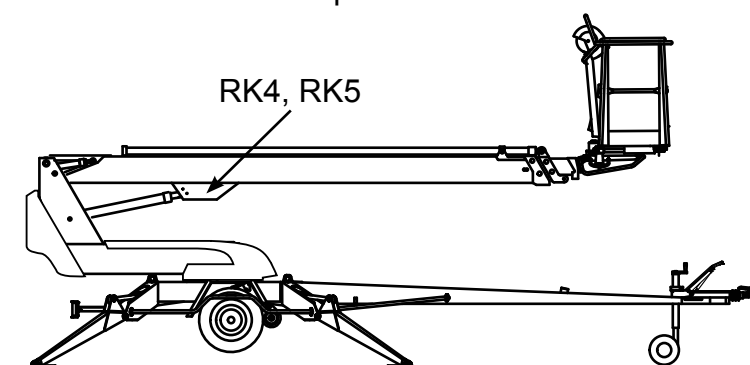

The green light in the control centre on the platform is lit, when the platform is within the allowed operating range.

The reach are limit switch **RK4** stops the movements that impair the stability of the lift (extending the telescope and lowering the boom) at a predetermined position.

Adjusted values of the limits:

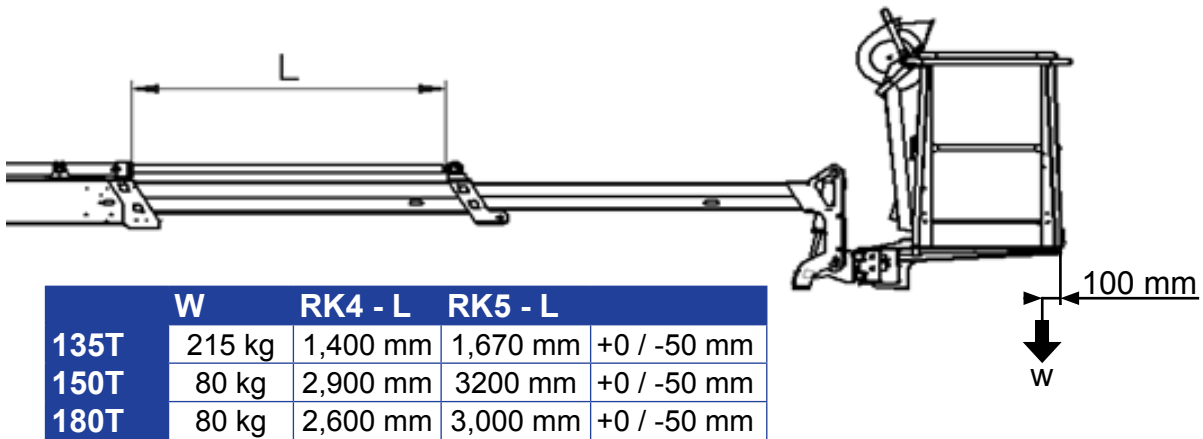

The red light flashes when the **RK4** has stopped the movement. While the red light is flashing, the lift can be operated in the direction where it stays inside the allowed outreach area.

The overload limit switch **RK5** backs up, if the **RK4**, for some reason, does not work. When activated, the RK5 switches on the buzzer on the work platform.

The operation of the overload limit switches is based on monitoring of the boom's lifting torque.

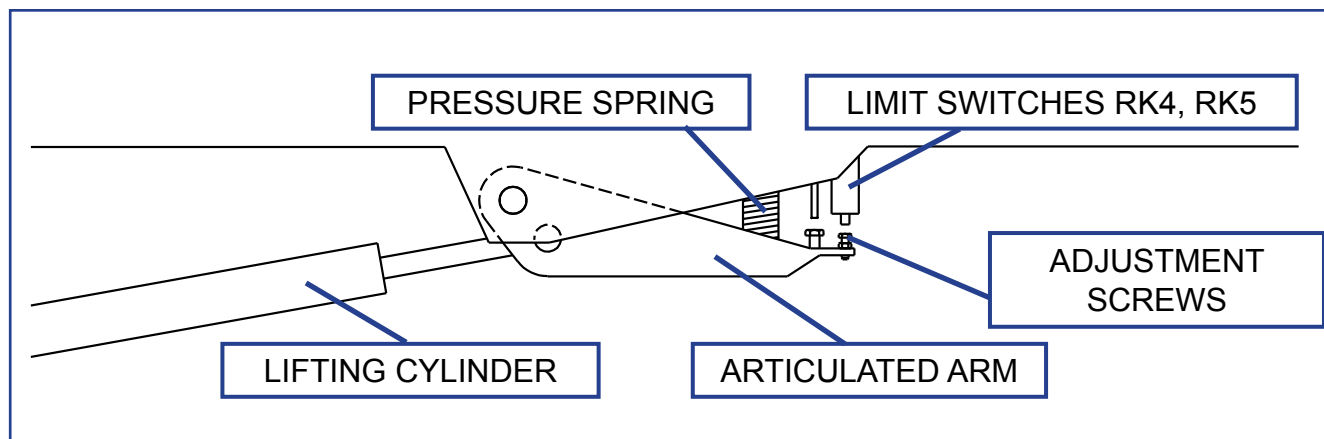

## DANGER

The limit switches must never be readjusted, nor the operation of the mechanism be impeded. **Risk of turning over the lift!**

## 4. Supervision of the telescope chain

The extension chains for the telescope are doubled. If the load-bearing chain slackens or breaks, the doubling chain prevents the movements of the telescope, and the safety switch RK7 breaks the emergency stop circuit.

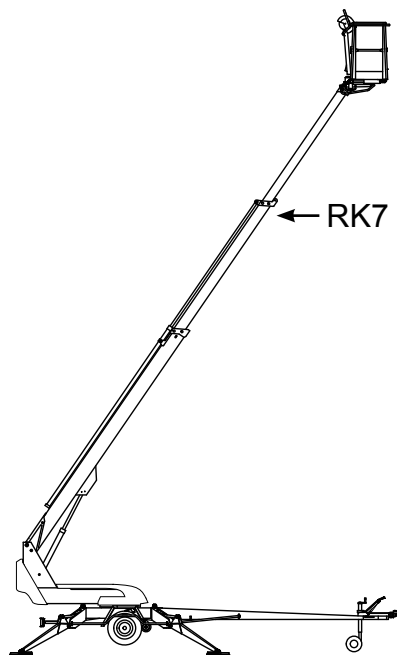
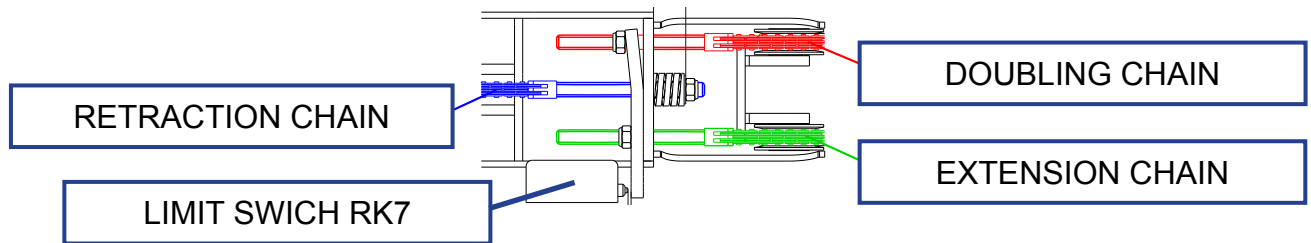

## 5. Preventing the inclination of the platform

The platform is levelled hydraulically by means of a so-called slave cylinder system, where the master cylinder controls the slave cylinder that inclines the work platform.

The levelling system comprises the following parts:

1. Master cylinder
2. Slave cylinder
3. Load regulation valve
4. Double load regulation valve
5. Electric directional valve

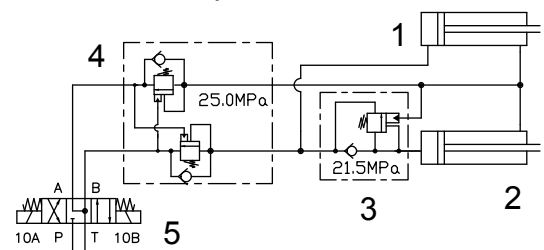

## 6. Safety devices for hose rupture

All the load-bearing cylinders are equipped with valves for rupture or leak in the hydraulic system, which prevent the load from falling.

Outrigger cylinders	Lock valves	Prevent the inching of the outriggers in either direction.
Lifting cylinder of the boom	Load regulation valve	Prevents the load from falling
Telescope cylinder	Load regulation valve	Prevents the inching of the telescope in either direction.
Levelling system	Load regulation valves	Prevents the inclination of the platform in either direction.

## 7. Emergency stop buttons

Depressing the emergency stop button, stops all the movements immediately and turns off the power unit. The button can be found at each control station. Once the button has been depressed, only the emergency descent functions remain operational.

The emergency stop button locks in the lower position, and it must be released before starting the power unit.

### **NOTICE**

If the unit does not start, make sure that the emergency descent button is not in the lower position at any of the control stations.



**BLANK**



## 4. STRUCTURE AND FUNCTIONS OF THE WORK PLATFORM

The denominations of the machine's essential parts and concepts, which are used later in these instructions, are described on the following pages.

### 4.1. STRUCTURE OF THE WORK PLATFORM

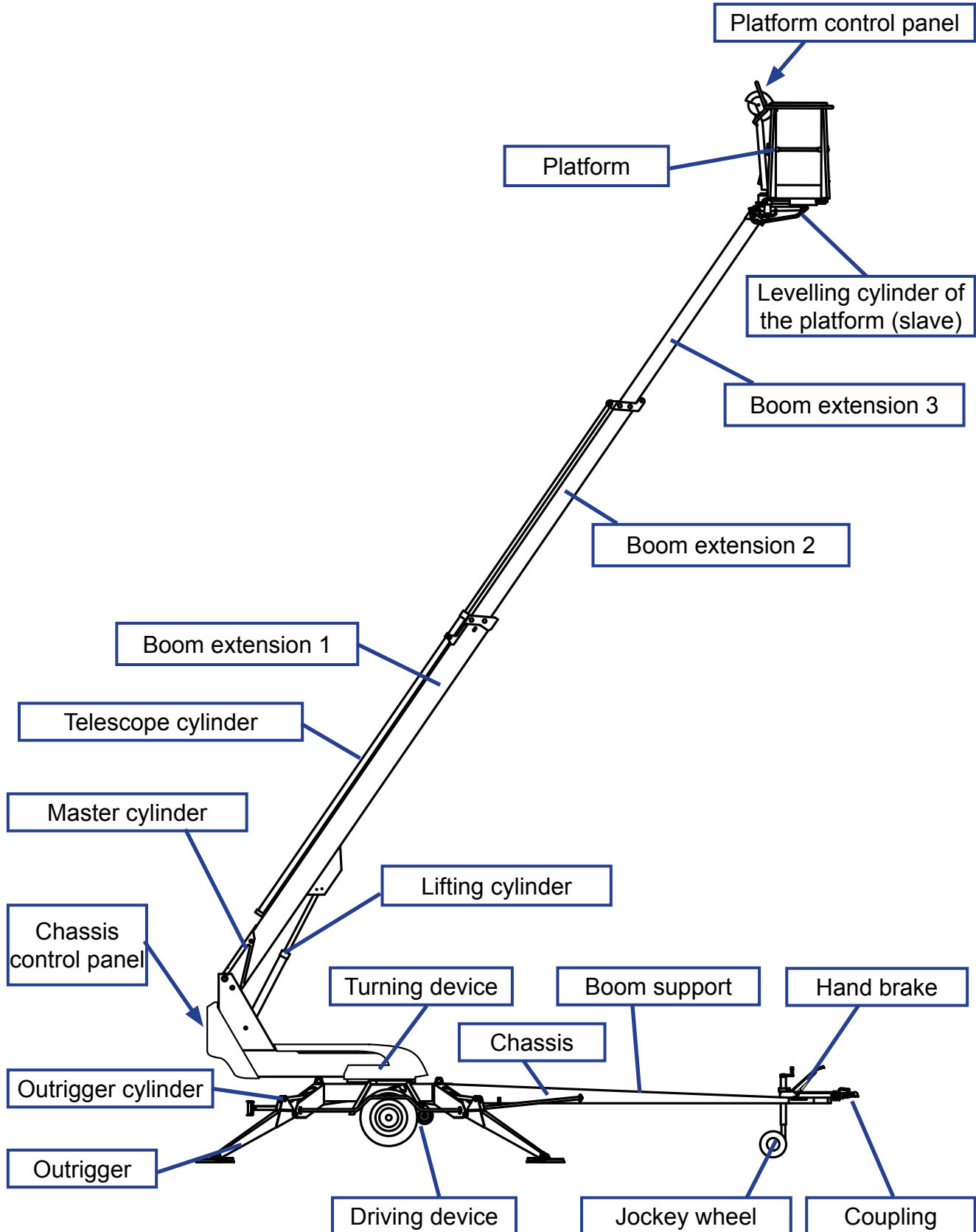

## 4.2. FUNCTIONS OF THE WORK PLATFORM

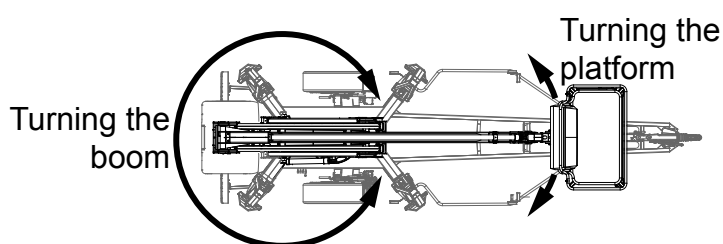
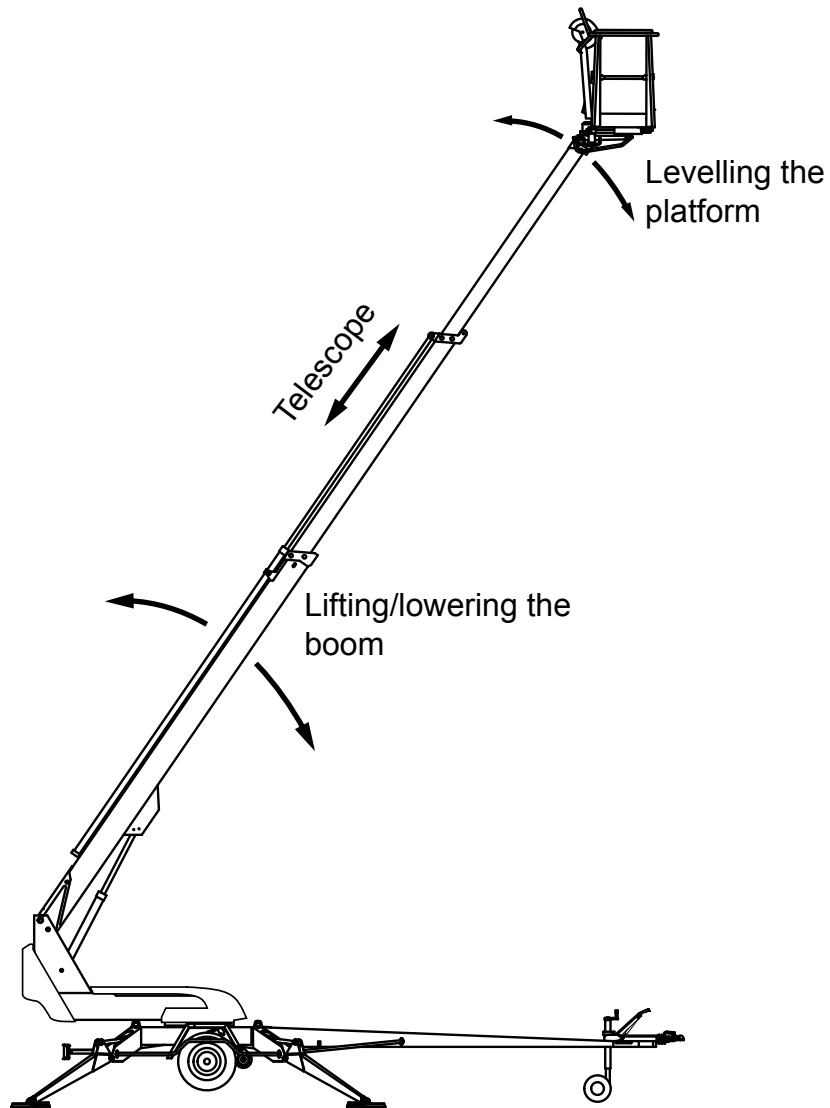
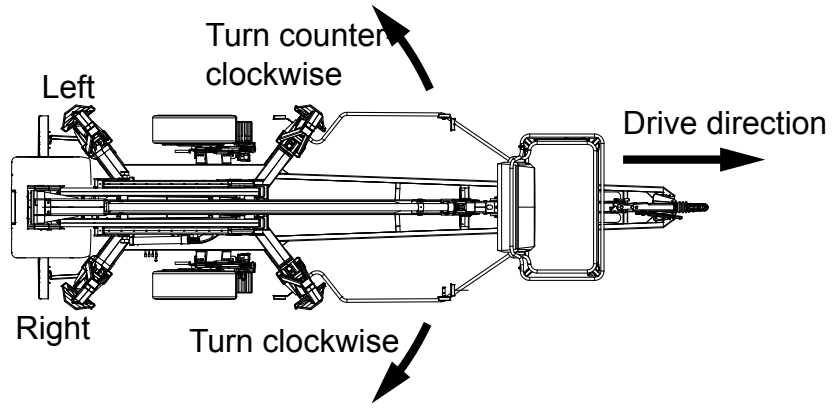

### 4.3. OPERATING CONTROLS FOR THE FUNCTIONS

#### 4.3.1. Operating controls in the chassis control centre

1	Selector switch	6	Pushbutton for retracting the telescope
0	OFF - power off	7	Lever switch for turning
1	Outriggers and drive	8	Lever switch for boom system
2	Controlling the boom from the platform panel	9	Lever switch for telescope
3	Controlling the boom from the chassis panel	10	Voltage meter
2	Start button	29	Stop button
3	Emergency stop	32	Lever switch for levelling of platform
4A	Signal light for outrigger limit switches	34	Hour meter
4B	Signal light for overloading (RK4)	40	Choke
5	Start button for emergency descent system		

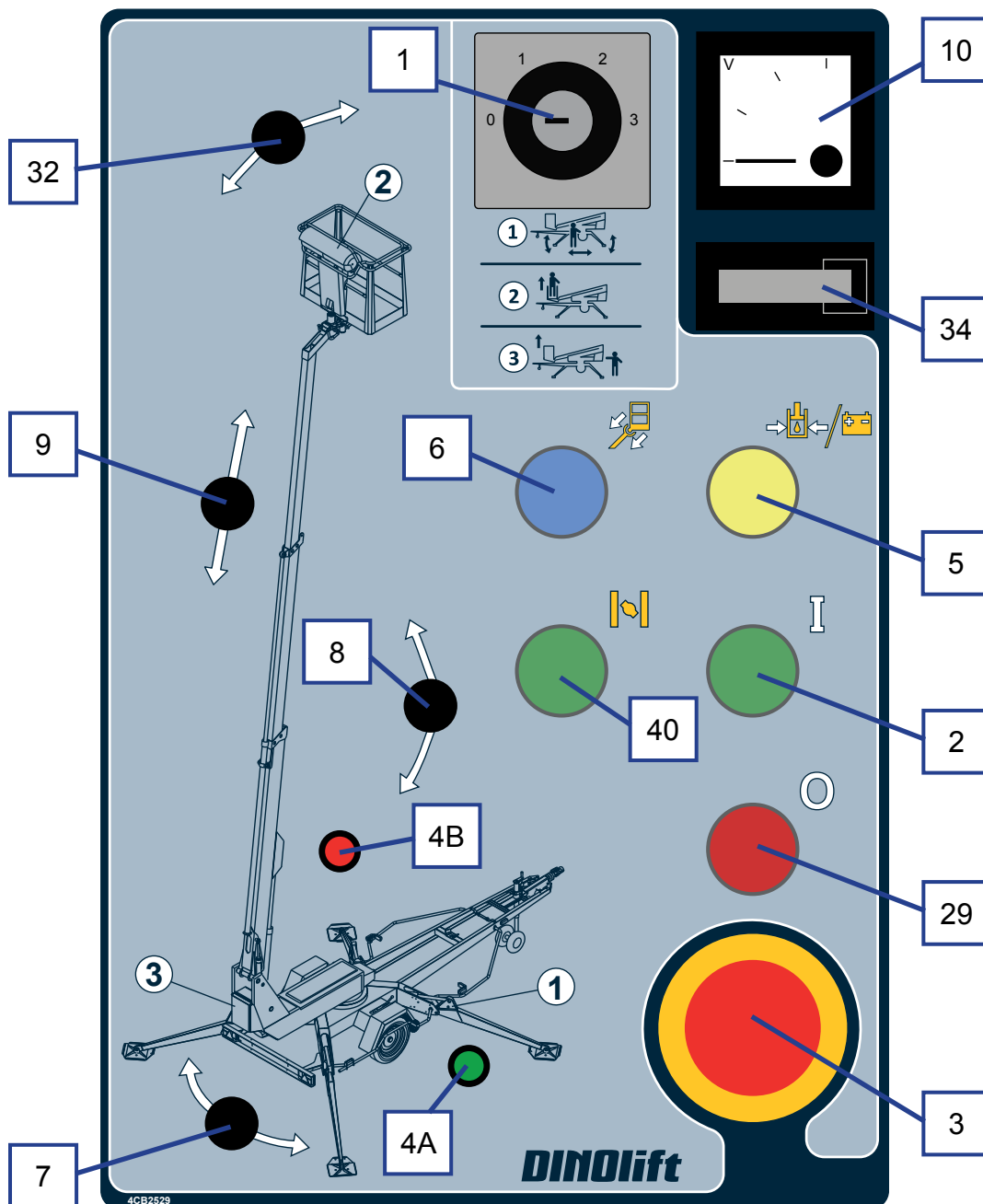



### 4.3.2. Operating controls for the driving device

26	Forward – backward
26 + 25	Drive to the left
26 + 24	Drive to the right

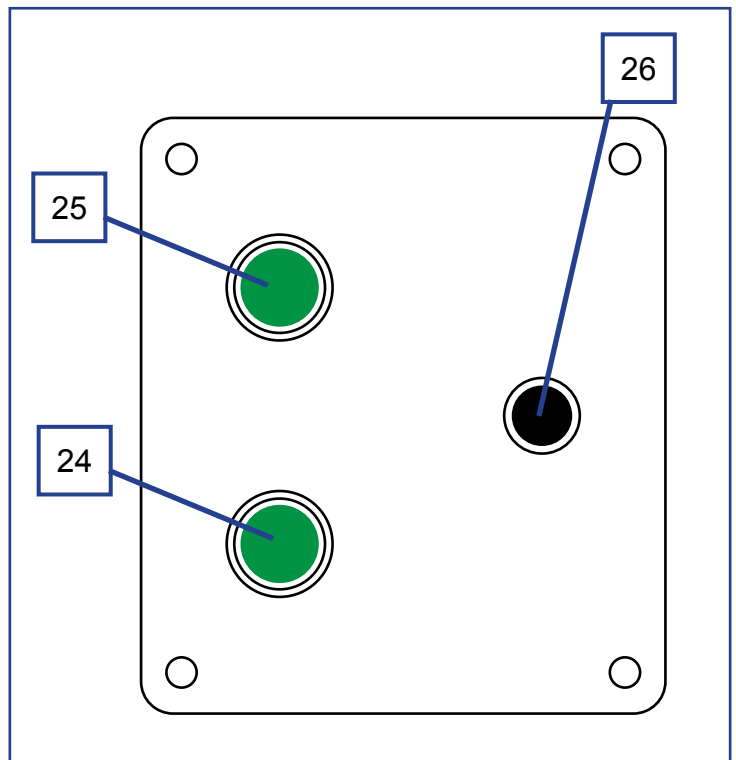

Remote control for the driving device is optional.  
Connect the remote control cable to the socket in the control box for the driving device

### 4.3.3. Operating controls for the outriggers

1	Rear outrigger, right
2	Rear outrigger, left
3	Front outrigger, left
4	Front outrigger, right
16	Position indicator of chassis

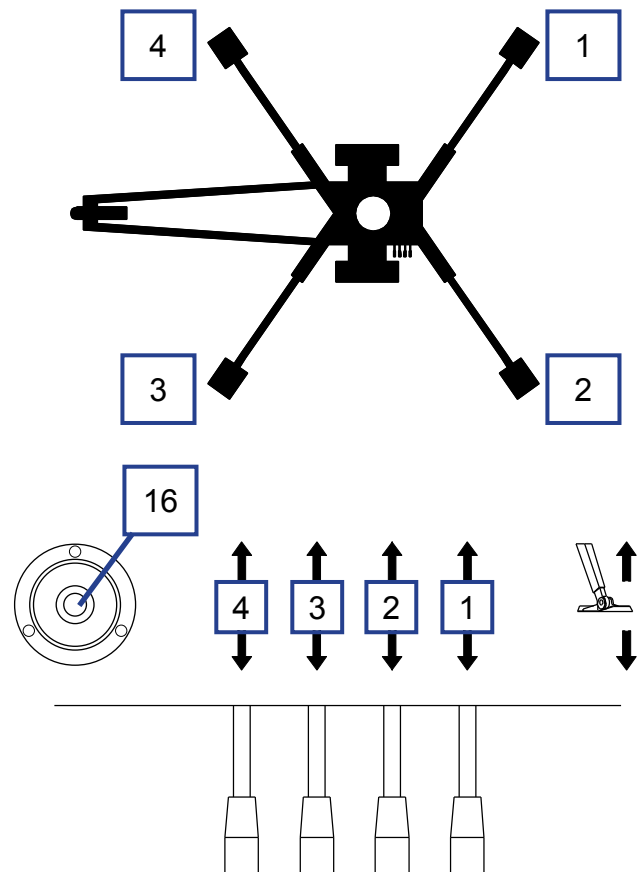

#### 4.3.4. Operating controls in platform control centre UCB

Close the cover of the chassis control centre before operating the controls on the platform. The cover must not be locked while the lift is in operation.

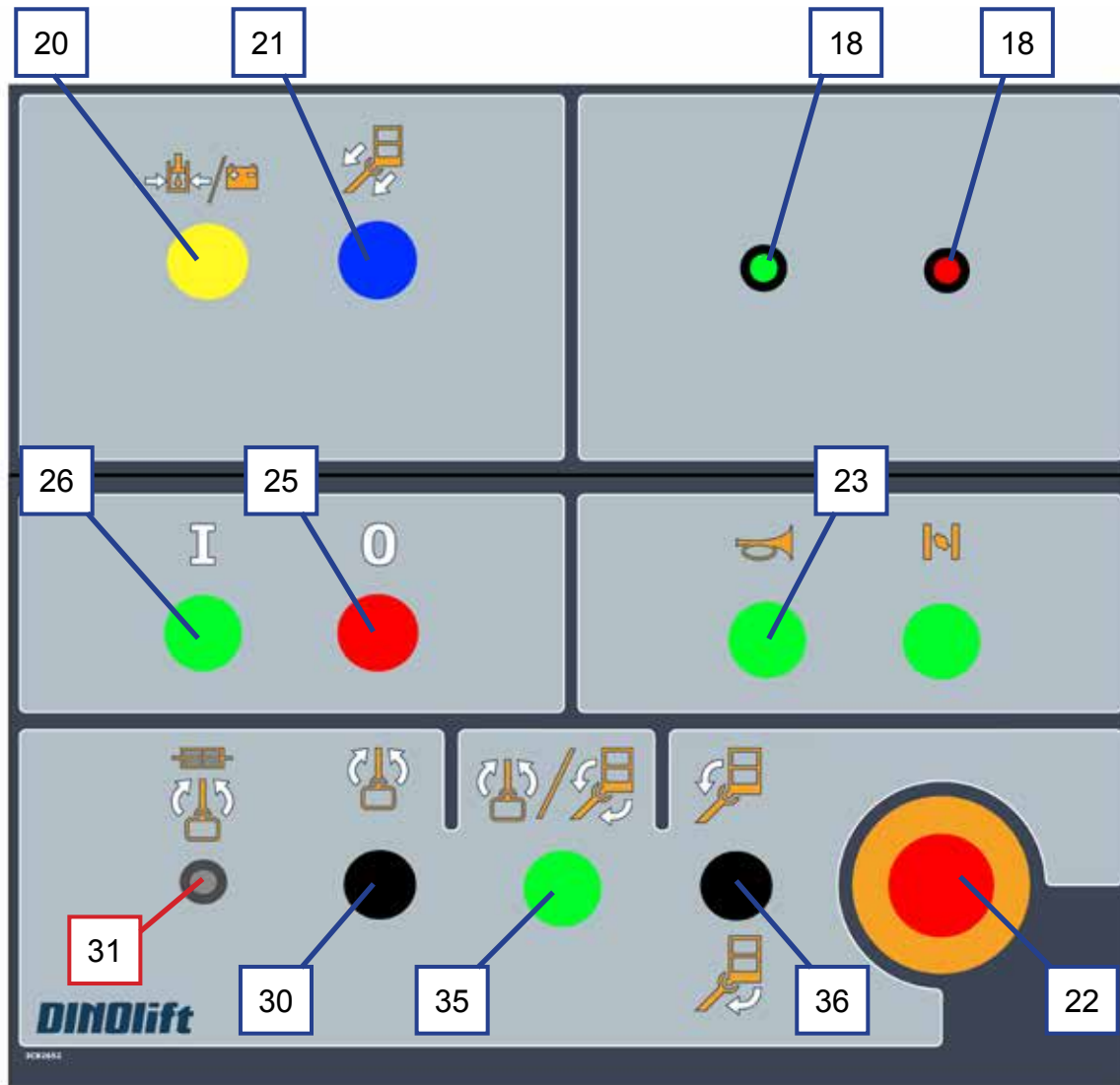

18	Signal lights	26	Start button for the engine
	Green – inside the allowed outreach range	30	Lever switch for turning of the platform (used simultaneously with pushbutton 35)
	Red – at the border of the allowed outreach range		
20	Start button for the emergency descent system	31	Fuse for turning of the platform
21	Pushbutton, retracting the telescope	35	Dead-man-switch (used in conjunction with 30 and 36)
22	Emergency stop		
23	Sound signal button	36	Lever switch for levelling of the platform (used simultaneously with pushbutton 35)
25	Stop button for the engine		
		PR	Socket outlet 230VAC/ (2 pcs.)

## 17. Control lever

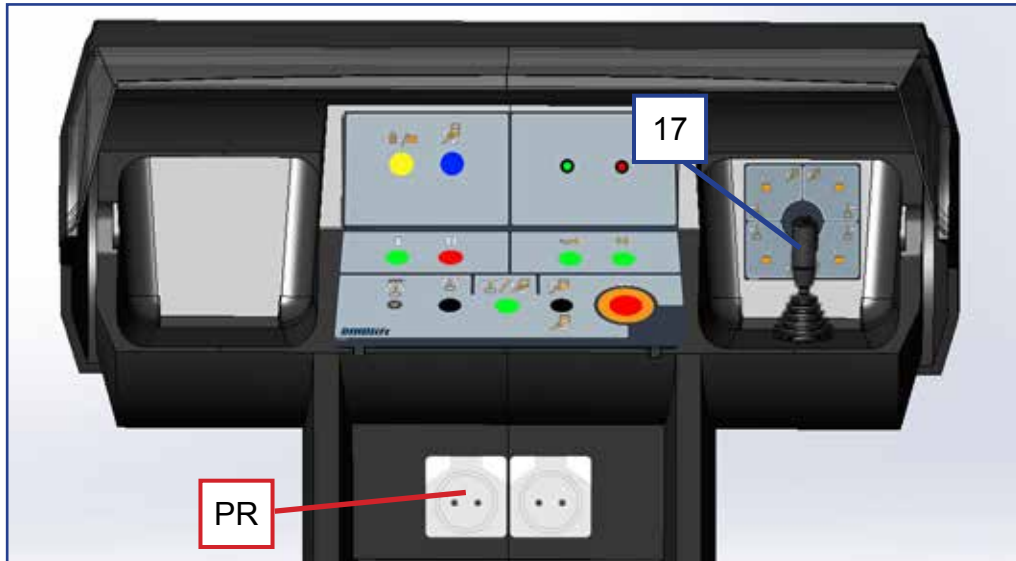

The functions to be controlled are selected using the "dead-man-buttons" at the end of the joystick. Always press the button first, and only after that, turn the handle. The safety connection prevents the movements, if the handle is turned before the button has been pushed down.

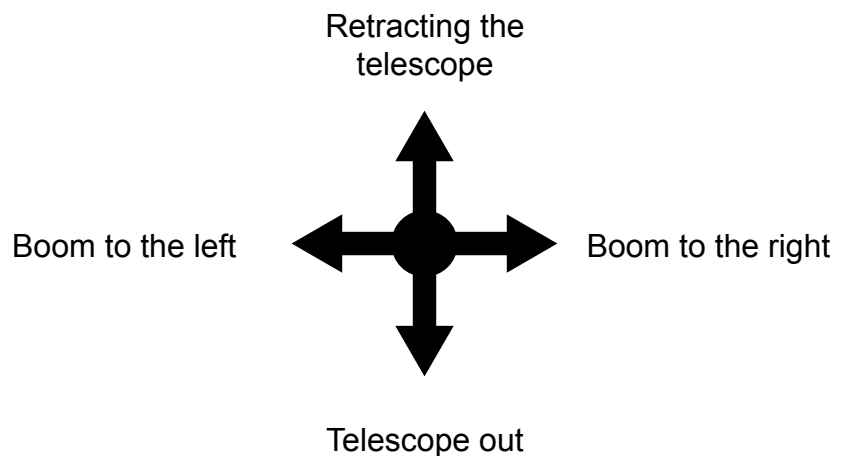
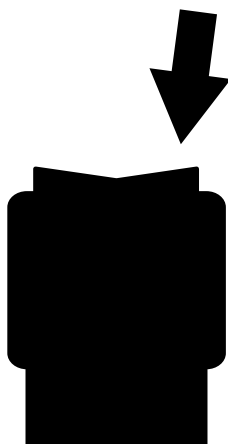
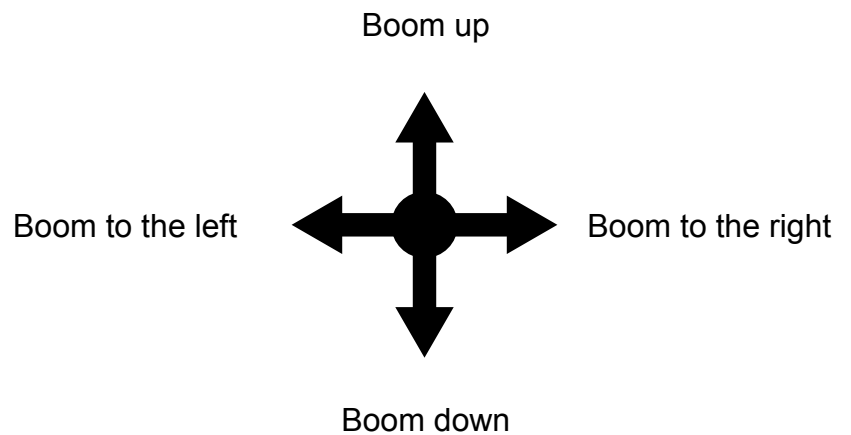
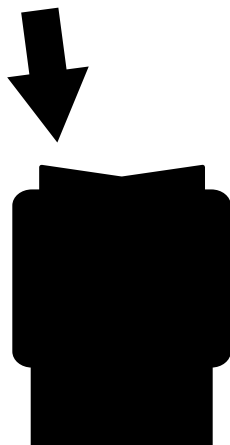

#### 4.3.5. Setup with two control levers (option)

A setup with two control levers is available as an option for the platform control centre.

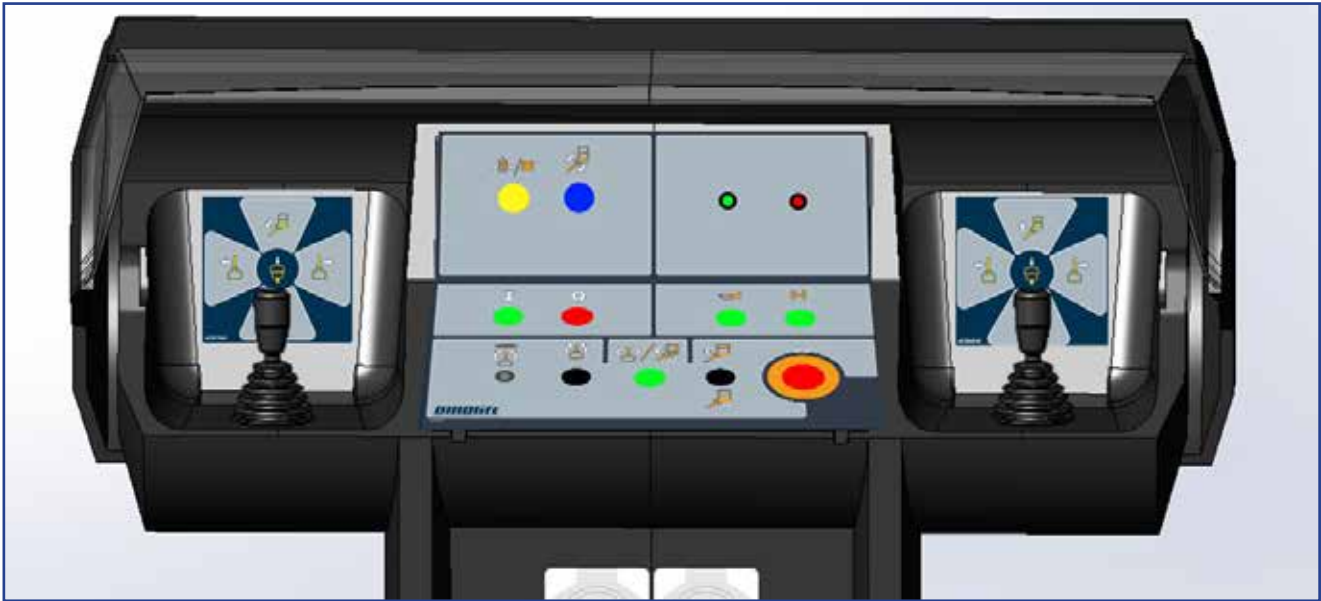

The left and right control levers (17 right/left) replace the normal control lever 17. Different functions are selected by turning the joystick in the desired direction of movement. Always press the button first, and only after that, turn the handle. The safety connection prevents the movements, if the handle is turned before the button has been pushed down.

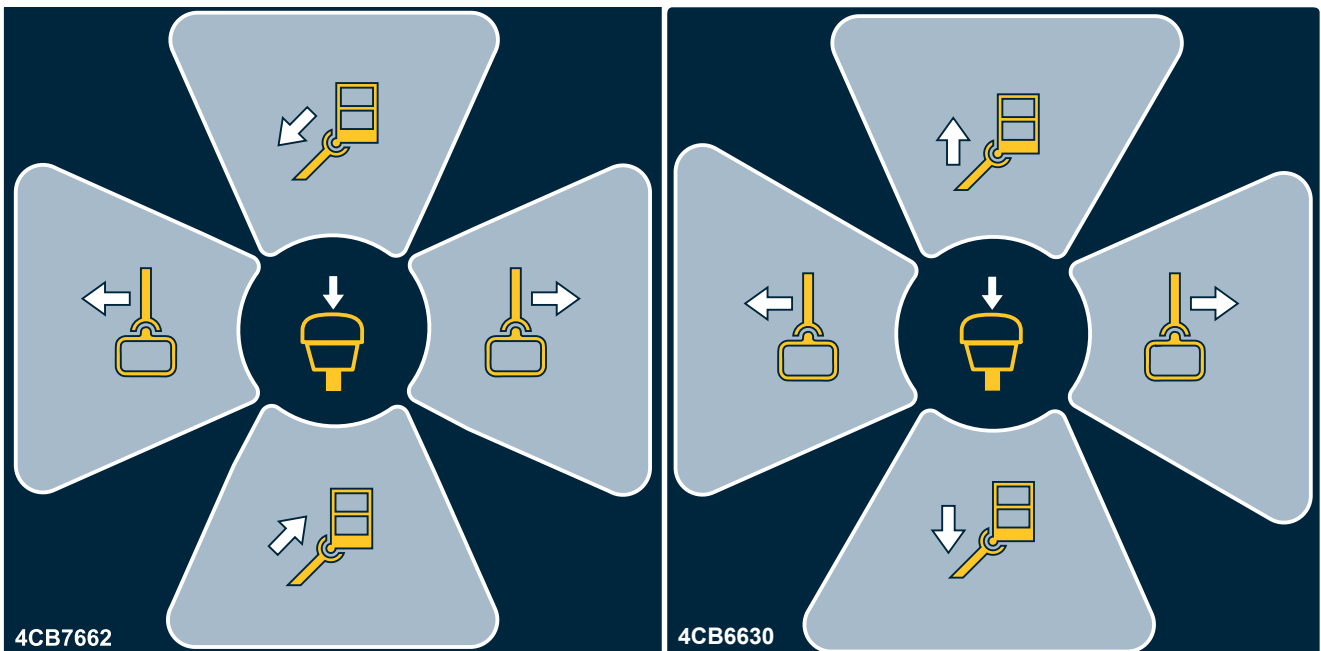

## 5. OPERATING INSTRUCTIONS

### 5.1. START-UP

#### **NOTICE**

Before operating the lift, perform all daily maintenance measures listed in the maintenance schedule.

The operator must do a worksite inspection and daily maintenance:

- at the beginning of each workday
- before operating the lift at a new worksite
- when the operator changes in the middle of a workday

#### 5.1.1. Worksite inspection

##### 1. General information

- Is the lift suited for the intended job?
- Is the performance of the lift sufficient for the job? (reach, loadability etc.)
- Is the position of the lift safe?
- Is the lighting on the worksite sufficient?

##### 2. Documents

- Are the Operation and Service Instructions for this lift present? (Manufacturer's instructions)
- Are inspections and servicing carried out in accordance with the instructions and have the defects affecting the safety been checked as repaired?
- (Inspection protocols)

##### 3. Structure (Visual inspection and operational test)

- General condition of the lift
- Operation and protection of the controls
- Emergency stop, signal horn and limit switches
- Electrical appliances and wiring
- Oil leaks
- Load markings and signs

##### 4. Operator

- Is the operator old enough?
- Has the operator received the required training?

##### 5. Special issues on the worksite

- Are there any additional regulations relevant to the worksite or the work?

### 5.1.2. Positioning the lift

1. make sure that the ground is even and hard enough to support the lift in a steady, level position.

Soil material	Density	Max. ground pressure	
		P	kg/cm <sup>2</sup>
Gravel	High density		6
	Medium density		4
	Loose		2
Sand	High density		5
	Medium density		3
	Loose		1,5
Fine sand	High density		4
	Medium density		2
	Loose		1
Sand / mud	High density (very hard to work)		1,00
	Medium density (hard to work)		0,50
	Loose (easily worked)		0,25

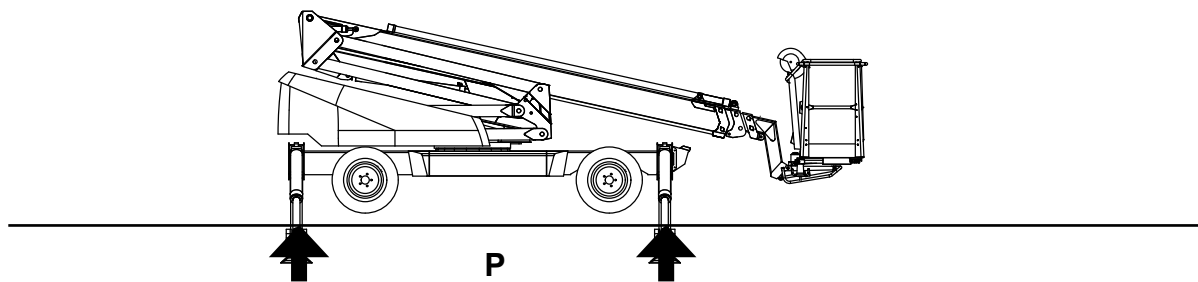

DANGER

If the ground is soft, use sufficiently large and sturdy additional plates under the support outriggers.

2. Drive the lift to the inspected lifting site
3. Engage the parking brake
4. Disconnect the lift from the towing vehicle

### 5.1.3. Connecting the power supply to the lift

#### A. POWERED BY AC-SUPPLY

While the mains voltage is plugged in, the operating voltage of 12 VDC is supplied by a power source.

- connect the mains cable to the power supply
- switch on the main switch
- with the electric motor at maximum load, the voltage must be 230 VAC (-10%/ +6%), the frequency 50 Hz, and rating of the fuse 10A (the length of the connecting cable has some effect)

#### B. POWERED BY COMBUSTION ENGINE (OPTION)

 <b>CAUTION</b>	<p>Protect your hearing while using the power unit (option) Sound pressure level at the lower control unit 98 dB.</p>
--------------------------------------------------------------------------------------------------	-----------------------------------------------------------------------------------------------------------------------

In the absence of the mains current, the operating voltage of 12 VDC is supplied by a battery.

- do not connect the mains cable (230 VAC)
- switch on the main switch
- open the fuel cock
- switch on the choke for the start by depressing the button on the cover of the centre

If the battery is flat, start the power unit by pulling the starter grip, and at the same time, keeping the button at the power unit's bed depressed. Pull the starter grip lightly until you feel resistance, then pull briskly. Do not allow the starter grip to snap back against the engine.

- After the power unit has started, set the engine revolutions to half of the maximum.

Leave the combustion engine running between the operations, because the battery will not be recharged, unless the combustion engine is running.

	<p><b>Close the fuel cock when stopping the combustion engine.</b>  <b>The fuel cock must be closed during towing of the lift.</b></p>
-------------------------------------------------------------------------------------	--------------------------------------------------------------------------------------------------------------------------------------------

To access the operating controls, open the LCB centre cover on the turning device

Check the condition of the battery to ensure the operation of the emergency descent system. The charge level of the battery is indicated by LEDs:

<b>Red LED</b>	Recharging in progress
<b>Green LED</b>	Battery almost fully charged.
<b>No LEDs</b>	Battery fully charged, maintenance recharging in progress

#### 5.1.4. Starting up

1. Turn the selector switch (1) to position 1.
2. Start the engine by depressing the button 2 (green).

The electric timer of the lift automatically disconnects the supply voltage (12 VDC) in about 1 hour after the electric motor or the combustion engine has been turned off.

Re-activate the power supply by pressing the start button either in the chassis control centre or in the platform control centre.

Petrol engine:

- turn off the choke
- adjust the engine speed

#### 5.1.5. Supporting the lift

1. Lower the front support outriggers (on the tow-bar side).
2. Lower the support outriggers in the rear. (do not damage the tow-bar jockey wheel).
3. Level the chassis with the outriggers with the help of the level gauge (16). The air bubble must be located inside the inner ring.
4. the signal light (4A, green) in the chassis control centre LCB is illuminated, when all the outriggers are in the support position and the limit switch circuit of the outriggers is closed

**Always check, before using the lift that:**

- the chassis is level, using the position indicator
- the wheels are off the ground
- the outriggers are firmly supported on the ground, and the limit switch circuit of the outriggers is closed (green LED in the chassis control centre is illuminated)



**DANGER**

**The operation is prohibited, if the lift is not properly supported and on a level position.**

**Observe the effect of ice, possible rain and inclination of the surface on the support (the support outriggers must not slip on the surface).**



## 5.2. OPERATION

### WARNING

Carry out all the daily maintenance routines and inspections in accordance with the maintenance instructions before operating the lift. **Failure to check the safety devices may cause a serious injury or make the consequences of an accident worse.**

### 5.2.1. Operating the lift from the chassis control centre

1. Turn the selector switch (1) to position "chassis control centre".
2. Lift the platform from the tow-bar and turn it to the side so that you can lower the boom.
3. Extend the telescope as much as is necessary to ensure that stepping onto the platform is safe.
4. Drive the boom and the platform using the control levers in the chassis control centre.



### NOTICE

Do not damage the tow-bar jockey wheel!

The boom movements are noticeably slower when the emergency descent system is used. The speed of the boom movements cannot be adjusted continually with the control levers when the lift is operated from the chassis control centre.

### 5.2.2. Operating the lift from the platform control centre

5. Turn the selector switch (1) to position "Platform control centre", and take away the key. Do not lock the protective cover of the chassis control centre.
6. Start using the lift normally.  
Step on the platform and drive the boom and platform movements as follows:

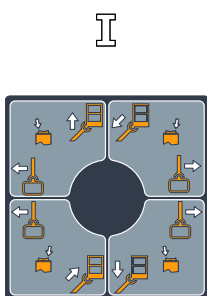

①

- Start the engine via the pushbutton.
- Drive the boom using the control levers.
- To operate the movements of the boom system, press first the rocker switch at the end of the control lever, and after that, move the control lever carefully in the desired direction of movement of the boom. The movement speed is adjusted steplessly.
- If you move the lever before pressing the rocker switch, the action will be deterred.
- Whenever possible, keep the boom short while lifting and lowering the platform.
- Operate the movements of the platform via the lever switches.
- Moving the platform via the lever switches requires that the dead-man-button 35 be depressed simultaneously.
- After the use, stop the engine via the pushbutton.



## WARNING

**Never add load onto the platform, while the red overload light is illuminated. Risk of turning over the lift!** Measures to be taken after an event of overloading:

Retract the platform to inside the operating range of the RK4 by pressing the “telescope in” button (the green light will be illuminated). After this, the lift may be operated normally.

7. With the boom slightly lifted and the telescope extended, make sure that the platform does not lower by itself while the operating controls are not being used.
8. Drive the platform to the work object.



## CAUTION

The lift itself, the buildings around it and other obstructions constitute a risk of getting squeezed. Hands and legs must be kept inside the work platform while the platform is moving. Also beware of any obstacles above the platform.

**IF THE SAFETY DEVICES OR THE EMERGENCY DESCENT SYSTEM ARE NOT WORKING, HAVE THEM REPAIRED BEFORE OPERATING THE LIFT.**

The platform movements can be operated with continually adjustable speed from the platform control centre (not from the chassis control centre). Only one movement can be operated at a time. If several control levers are operated simultaneously, only the movement with the least resistance will operate.

### Observe when lifting the platform

- the operating range of the platform depends on the load (see “Technical Data”) and is monitored by the safety limit switches RK4 and RK5, which are located under the protecting cover
- The limit switches must not be adjusted or modified. The inspection and adjustment may only be carried out by an authorized serviceman.

### Working a long time in the same position

- When the weather is warm, and the platform is kept for a longer period in the same position, it is not necessary to let the engine run continuously.
- when the weather is cold, it is, however, recommended to let the engine run to keep the hydraulic oil warm
- keep the battery sufficiently charged even during long-term work in the same position. As necessary, the state of charge of the battery must be ensured by power supply either from mains or from power pack.
- check the stability and condition of the base regularly during the operation, taking into account the weather and ground conditions
- the electric timer of the lift automatically disconnects the supply voltage (12 VDC) in about 1 hour after the electric motor or the combustion engine has been turned off.
- Re-activate the power supply by pressing the start button either in the chassis control centre or in the platform control centre.

## When moving the platform, remember the following

- beware of high voltage power lines
- do not touch open electric wires
- do not throw objects from the platform
- do not damage the lift
- do not damage other devices



## DANGER

**It is strictly prohibited to take additional load in the upper position.**

Do not exceed the lateral force (400N), or load the platform vertically more than allowed.

Lowering the platform to transport position:

Always retract the telescope completely and turn the platform perpendicular to the boom before lowering the boom onto the transport support.

## NOTICE

Do not damage the tow-bar jockey wheel while lowering the platform to the transport position!

## When leaving the lift

- drive the lift to a safe position, preferably to the transport position
- switch off the power unit
- prevent unauthorized use of the lift by locking the control centre cover

### 5.2.3. Special instructions for winter use

**The lowest allowed operating temperature of the lift is -20 °C**

In cold conditions, carry out the following special actions in addition to the normal start-up procedure:

1. Let the power pack run for a few minutes before starting the movements.
2. To ensure the proper operation of the valves, do first a few warm-up movements to change warm oil in the cylinders.
3. Check that the limit switches and the emergency descent devices are operational and clean (from dirt, snow, ice, etc.).
4. Protect the control centre and the platform from snow and ice whenever they are not in use.
5. Ensure that the batteries are charged. Flat batteries freeze easily.



**Always keep the lift free from dirt, snow etc.**

### 5.2.4. Ending the work

At the end of the workday:

1. Retract the telescopic boom fully.
2. Check that the platform is perpendicular to the boom.
3. Lower the boom/platform onto the support on the tow-bar. The limit switch on the transport support prevents the operation of the support outriggers if the platform is not down.
4. Close the control centre cover on the work platform.
5. Turn the selector switch to position OFF, and turn off the main switch.
6. If you want to recharge the battery, leave the mains cable connected; otherwise disconnect the lift from the mains supply.
7. Make sure that the covers are locked.

## NOTICE

To ensure proper operation and long service life of the batteries, it is recommended to always recharge them at the end of each workday, even though there was still plenty of charge left. Storing the batteries flat shortens their service life, and flat batteries also freeze easily.

### 5.3. TRANSFERRING THE LIFT

The lift can be transferred by towing or using its own driving device.



**The lift may only be moved in the transport position. No persons or load are allowed on the platform during the transportation.**

#### 5.3.1. Preparing the lift for transport

During transfer, the lift must always be in the transport position.

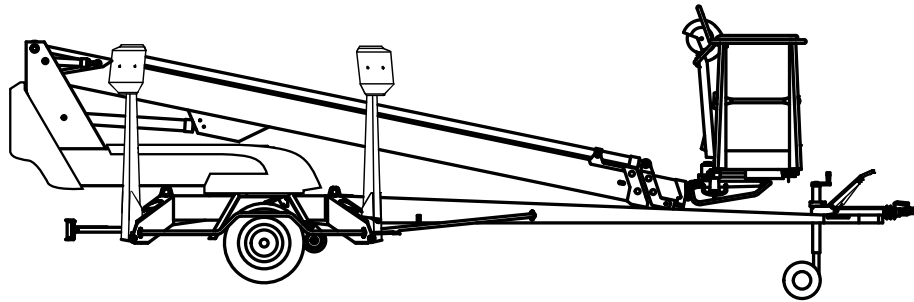

Prepare the lift for the transfer as follows:

1. Retract the telescopic boom fully.
2. Check that the platform is perpendicular to the boom.
3. Lower the boom/platform onto the support on the tow-bar. The limit switch on the transport support prevents the operation of the support outriggers if the platform is not down.
4. Close the control centre cover on the work platform.
5. Turn the selector switch (1) to position "outriggers and drive".
6. Lift the support outriggers.  
Lift first the rear support outriggers (do not damage the rear lights), and then the front support outriggers (do not damage the jockey wheel).
7. Make sure that the covers are locked.

If you intend to tow the lift:

8. Apply the parking brake.
9. Make sure that the driving device is disconnected.
10. Turn the selector switch to position OFF and disconnect the lift from the power supply.

### 5.3.2. Using the driving device

The hydraulic driving device is intended for moving the lift within the work area if the towing vehicle cannot be used.



**During transfer in rough terrain, try to stay above the machine.**

1. Turn the selector switch (1) to position "outriggers and drive".

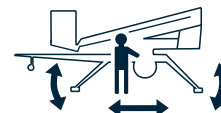

2. Start the electric motor.

(With combustion engine, start the power pack and set the engine revolutions to 3/4 of the maximum. The running speed of the power pack affects the driving speed.)

3. Make sure that the platform is in the transport position and the outriggers are lifted in the upper position

4. Make sure that the mains cable is long enough to cover the whole travel distance – or that the cable has been disconnected.

5. Switch the driving device to the drive position.

6. Release the parking brake

7. Transfer the lift using the operating controls of the driving device.

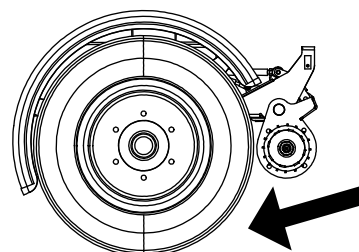

## CAUTION

**Do not drive the jockey wheel into obstacles or potholes.** If one of the wheels bumps into an obstacle, the lift may turn abruptly.

After the driving:

- Apply the parking brake.
- Disengage the transmission.
- Disconnect the driving device from the tyre.

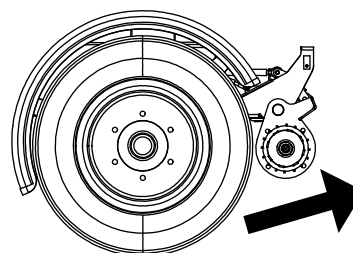

## NOTICE

**Be careful not to damage the jockey wheel tube by extending it too much.**

When moving the lift using the driving device, a suitable length for the jockey wheel's stem can be achieved by adjusting the gap between the lower surface of the tow-bar/brake rod and the wheel to 1-3 cm. Then the wheel may turn freely.

## On a slope:

1. When driving on a slope, the tow-bar must always point towards the descent. Never drive with the driving device with the tow-bar pointing towards the ascent.
2. Always place chocks under the wheels before disconnecting the device from the towing vehicle.
3. Always apply the handbrake before disconnecting the lift from the towing vehicle.
4. Only use the handbrake as a parking brake or for emergency stopping.
5. When transferring the lift using the driving device:
  - take care not to allow the wheel to roll over your foot
  - look out for sudden sideways movements of the tow-bar
  - be careful not to cause danger to other people and the environment
6. Do not move the device on a slope using only hand-power. You may lose control over it and cause an injury.
7. Never park a vehicle combination on a slope.  
Never leave the lift on a slope being supported only by the self-braking action of the driving device.

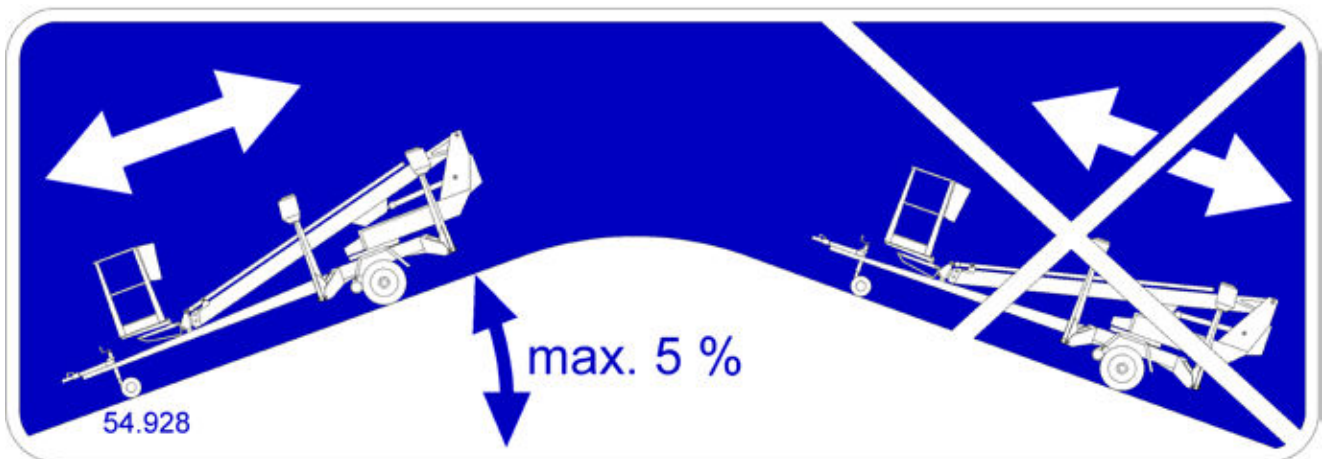

**Do not drive downhill with the driving device, if the inclination of the surface is more than 5 per cent, (corresponding to a descent of 0.5 m over a distance of 10 m). If the gradient of the surface is greater than this, you may lose control of the device.**

### 5.3.3. Towing the lift

Connecting to the towing vehicle

1. Lift up and push forward (in the driving direction) the handle of the ball-coupling. Now the ball-coupling is released.
2. Press the ball-coupling onto the towball using only a little force. The connection and locking take place automatically.



**Always make sure, after the connection, that the ball-coupling is properly locked.**

3. Connect the emergency stop wires and light plug to the vehicle. Check the cable for chafing and proper operation of the wires.
4. Check the operation of the lights.
5. Carefully release the parking brake and make sure that its locking is in order and that its handle stays in the lower position.
6. Lift up the jockey wheel to the transport position.



**Clean and lubricate the ball-coupling regularly.**

In particular, if you are parking or disconnecting the lift from the towing vehicle on a slope, apply the parking brake as firmly as possible. After having applied the parking brake, push the lift backward to make the reverse automatics release the brake shoes. The spring cylinder pulls the parking brake tighter, and the brakes of the vehicle will again be properly engaged.

Adjust the brakes according to the service instructions.

Place chocks under the wheels as an additional precaution.

## NOTICE

Observe the national traffic regulations, the local and worksite-specific instructions, as well as the instructions concerning the towing vehicle.

### Always ensure before towing:

- transport position of the outriggers
- locking of the ball-coupling
- operation of the lights, connection of the cable
- that the parking brake is disengaged
- condition and pressure of the tyres
  - rear axle 450 kPa (4.5 bar)
  - jockey wheel 250 kPa (2.5 bar)
- attachment of the safety wire
- locking of the brakes after the transportation
- locking of the jockey wheel in its upper position
- that the driving device is disconnected from the wheel
- that there is no load on the platform



**Always use chocks under the wheels when disconnecting the lift from the car.**



### 5.3.4. Lifting the device

The device can be lifted using the lugs shown in the picture. The lifting lugs are located symmetrically on both sides of the lift.

During lifting the aerial work platform must be in the transport position. Remove all loose material from the top of the frame structures and the work platform before lifting.

Use for lifting a suitable crane with sufficient capacity and relevant accessories. Check the weight of the lift in the technical specifications.



**Be careful not to damage the device during the lifting operation.**

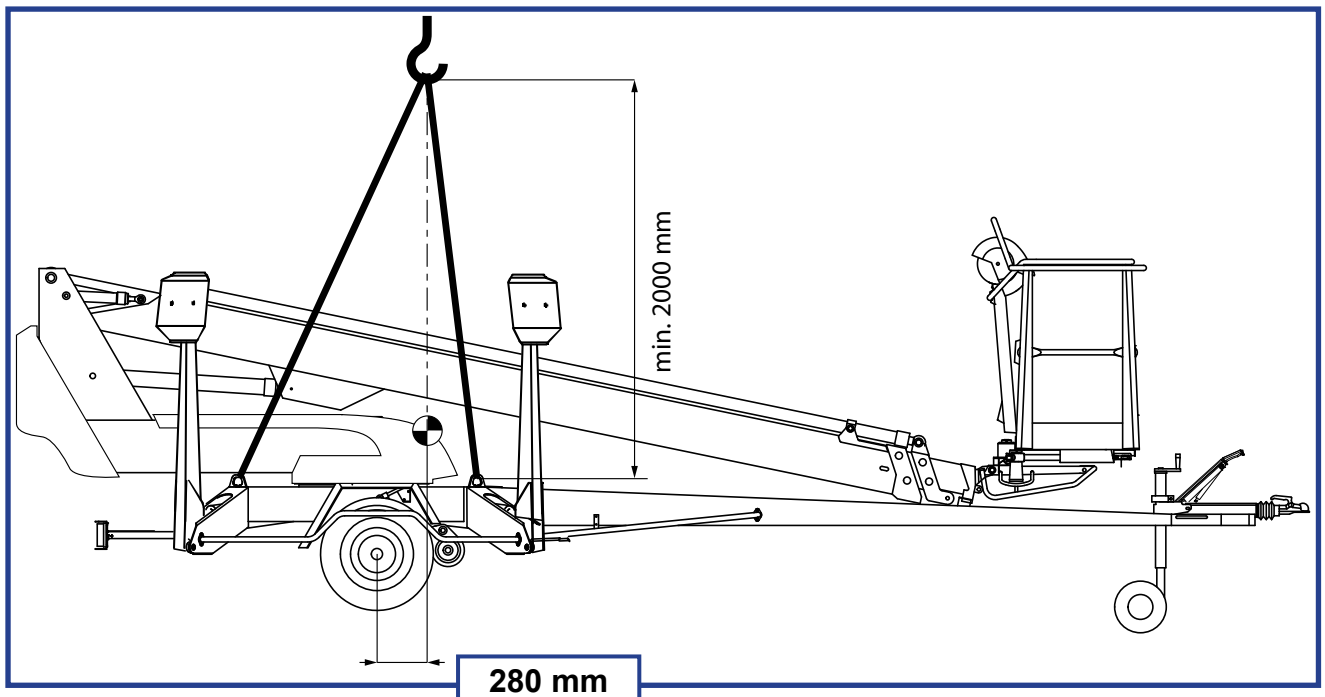

#### 5.4. LONG-TERM STORAGE

Clean the machine carefully, lubricate it and apply protective grease to it before putting it into storage for a longer period of time (see point “Lubrication plan”). Repeat the cleaning and lubrication procedures when you resume the operation.

### ***NOTICE***

If you leave the lift standing for a longer period of time, for example over the winter, we recommend propping it up to release any load from the wheels.

The periodic inspections must be executed following the steps described in the instructions.



**BLANK**



## 5.5. IN CASE OF EMERGENCY

### 5.5.1. When at risk of losing the stability

Reduced stability can be caused by a fault in the lift, the wind or other lateral force, collapse of the standing base or negligence in providing sufficient support. In most cases one sign of reduced stability is the inclination of the lift.



1. If there is time, try to find out the reason for the reduced stability and the direction of its effect. Warn other people on the worksite using the alarm signal.

2. If possible, reduce the load from the platform in a safe manner.



3. Aja teleskooppi sisään sivu-ulottuman pienentämiseksi. Avoid abrupt movements.

4. Turn the boom away from the danger zone, i.e. to a position where the stability of the lift is normal.

5. Lower the boom.

If the stability has been lost as a result of a fault in the lift, repair such a fault immediately.



**Do not use the lift until the fault has been repaired and the condition of the lift has been verified.**

### 5.5.2. In case of overloading



1. If there is time, try to find out the reason for the reduced stability and the direction of its effect. Warn other people on the worksite using the alarm signal.

2. If possible, reduce the load from the platform in a safe manner.



3. Reduce the outreach to the side by retracting the telescopic boom using the emergency descent system. Avoid abrupt movements.

4. The green light will illuminate as soon as the overloading situation is reset. After this, the machine may be operated normally.

### 5.5.3. In case of power failure

As a precaution against power failure or other malfunction of energy supply, the lift is equipped with a battery operated emergency descent system.



1. Start the emergency descent system via the pushbutton. The emergency descent system is operational only when the pushbutton is being depressed.



2. Use the “telescope in” pushbutton, if the set value of the RK5 has been exceeded.

3. In any other case, operate the movements using their regular control levers. Using the emergency descent, retract first the telescope completely, then lower the boom. Finally, turn the boom.

4. Establish the reason why the energy supply was interrupted.

**Note!** The emergency descent system can also be used for raising the support outriggers to the transport position

Always check the condition of the battery for the emergency descent system before putting the lift into operation.

(See point “Operation of the safety devices”)

### **Setup of the emergency descent system**

- 12 V, 44 Ah
- recharger
- hydraulic unit 12 VDC

### **The hydraulic unit comprises**

- pressure relief valve, set value 16 MPa (160 bar)
- check valve
- direct current motor of 800 W

### **5.5.4. In case of malfunction, when even the emergency descent system is not operational**

If not even the emergency system is working, try to warn other personnel present on the site or call for more help. When help arrives, try to

- restore the power supply required for normal operation
- make the emergency descent system operational by, for example, changing the battery
- resume the lift's normal operation by other means

Always check the condition of the emergency descent system battery before putting the lift into operation (see point “Operating from the chassis control centre”).

## 6. INSTRUCTIONS FOR FAULT-FINDING

FAULT	REMEDY
-------	--------

### 1. The electric motor does not start from its start button although the selector switch 1 is in the position that enables operation from either the chassis or the platform control centre

The emergency stop button has jammed in the lower position.	Pull up the button and re-start the motor from the start button.
Fuse F1 has blown.	Replace the fuse (10A).
No mains supply (230 VAC) to the selector switch.	Check the extension cords, possible distribution boards and fuses.
Fault current safety switch has tripped.	Reset the fault current safety switch.
No direct-current supply (12VDC).	Main switch has been turned off, turn on the switch.

### 2. No power supply to the lift, although the main switch is on and the selector switch is in the position that enables operation from either the chassis or the platform control centre

Power supply has not been activated.	Press the start button to activate the power supply.
Battery is flat.	Recharge the battery.

### 3. Power unit does not start

Battery is flat.	Recharge the battery.
The mains cable is plugged.	Disconnect the plug from the mains.
No supply of direct-current (12VDC), because the main switch is disengaged.	Switch on the main switch.

### 4. Power unit cranks but does not start

Fuel tank is empty.	Fill the fuel tank.
Choke is off.	Press the choke button (cold engine). 
Throttle lever is in idling position.	Increase the engine revolutions.

### 6. None of the boom movements is operational, although the electric motor is running and the selector switch is in the correct position (operation from the chassis control centre or the platform control centre)

The lift has been overloaded.	Reduce the platform load or	
	Retract the telescope until the platform returns inside its operating range (the green light in the platform control centre is illuminated).	

FAULT	REMEDY
-------	--------

## 7. Outriggers do not move

The boom is not resting on the transport support.	Drive the boom onto the transport support.
The selector switch is in the wrong position.	Turn the selector switch to the correct position.
Limit switch on the boom support has not closed.	Drive the boom onto the transport support.

## 8. Malfunctions of platform movements – only one of the movements can be operated

Lifting and lowering of the boom and the extension of the telescope are not operational, the red light is illuminated on the platform and in the chassis control centre, and the buzzer is audible.	The boom has been overloaded; retract the telescope and retry the operation (automatic reset).
-----------------------------------------------------------------------------------------------------------------------------------------------------------------------------------------------------	------------------------------------------------------------------------------------------------

## 18. Driving device is not operational, although the selector switch is in the correct position

Boom is not resting on the transport support.	Drive the boom onto the support.
-----------------------------------------------	----------------------------------

## 24. Wheel brakes overheat

Parking brake not completely released.	Release the parking brake completely.
----------------------------------------	---------------------------------------

## 25. Ball-coupling is not locked

Inner parts of the ball-coupling dirty.	Clean and lubricate.
Tow-ball of the towing vehicle too large.	Make sure that the towing ball of the towing vehicle is the right size for the lift's tow hitch.  According to DIN74058, the diameter of the ball must be max. 50 mm and min. 49.5 mm.

**In all other fault conditions, the lift must be submitted to a qualified DINO service provider.**

### To avoid malfunctions

- Follow the operating instructions
- Beware of dangerous situations, which can damage the lift
- Keep the lift clean and protect it against moisture

**NOTES**



**NOTES**

## 7. MAINTENANCE SCHEDULE

Maint.	Schedule	Person responsible	Reference
A	Daily	Operator	Operating instructions
B	1 month / 100 hours*	Competent person who is familiar with the lift	Maintenance instructions
C	6 months / 400 hours*	Competent person who is familiar with the lift	Maintenance instructions
D	Annually / 800 hours*	Skilled technician who is well familiar with the structure and operation of the lift	Maintenance instructions
E	As needed	Skilled technician who is well familiar with the structure and operation of the lift	Maintenance instructions

\* Service must be performed every indicated month or operating hour interval, whichever comes first.

### NOTICE

In addition to the daily maintenance routines according to the maintenance schedule, every operator is obliged to perform a site-specific worksite inspection.

T = Check (general checking of condition).

P = Thorough Inspection. To be performed following the separate procedure described in the maintenance instructions.

V = Grease

S = Carry out replacements, repairs or other maintenance tasks described in the instructions

Maintenance item	A	B	C	D	E
1 Condition of chassis structures, boom and work platform	C	C	C	I	
2 Bearings of the overload protection device joint		G	C/G	C/G	
3 Bearings of outriggers and outrigger cylinders		G	C/G	I/G	
4 Bearings of outrigger footplates and moving parts of outrigger limit switch system		G	C/G	I/G	
5 Bearings of boom and articulated arms		G	C/G	C/G	
6 Bearings of the platform		G	C/G	C/G	
7 Bearings of the levelling cylinders		G	C/G	C/G	
8 Bearings of the lifting cylinder		G	C/G	C/G	
9 Sliding surfaces / rolls of the telescope		C/G	C/G	C/G	
10 Bearings of the telescope cylinder			C/G	C/G	
11 Condition of cylinders				I	
12 Flyer-chain			G	I/G	
13 Slide pads and sliding pad clearances		C	C	C	
14 Turning device			G	I/G	
15 Electro-hydraulic rotating adaptor				C	
16 Tyres and tyre pressures	C	C	I	I	
17 Coupling / overrun device		C	G	I/G	
18 Jockey wheel slide and threads				I/G	
19 Brakes			C	C	

Maintenance measures		A	B	C	D	E
20	Axles and suspension				I	
21	Driving device		C	G	I	
22	Lights	C	C	C	I	
23	Hydraulic oil	C	C	C	D	
24	Hydraulic hoses, pipes and fittings	C	C	C	I	
25	Condition and attachment of battery, electrical devices and wiring		C	C	I	
26	Hydraulic pressure				I	
27	Condition of safety limit switches				C	
28	Operation of safety limit switches	C	C	C	I	
29	Operation of overload protection device			C	I	D
30	Load holding and load regulation valves			C	C	
31	Platform levelling system		C	C	C	
32	Platform control devices	C			I	
33	Emergency descend, emergency stop and sound signal	C	C	C	C	
34	Signs, labels and machine plates	C	C	C	C	
35	Instruction manuals	C	C	C	C	
36	Test loading				I	
37	Corrosion protection				C	D
38	Movement speed adjustment					D
39	Special inspection					D

Always lubricate the lift and apply a protective grease film immediately after the washing.

The lift must always be subjected to a special inspection after an exceptional event. Special inspection is required if the lift has been damaged in a manner, which may affect its load-bearing capacity or safe operation. Consult the maintenance manual for more detailed instructions.

## NOTICE

If the lift is equipped with a petrol-driven power pack, then carry out, in addition to the normal maintenance routines, also the service measures prescribed in the operating and service instructions for the power pack.

## NOTICE

Under demanding conditions where moist, corrosive substances or corrosive climate may speed up the deterioration of the structures and induce malfunctions, the maintenance intervals must be shortened, or the influence of corrosion and malfunctions must be reduced by using appropriate protective means.

## 7.1. SCHEDULE FOR INSPECTIONS REQUIRED BY THE AUTHORITIES

**Inspections must be performed in accordance with local, state or federal regulations, legislation, directives, standards.** The manufacturer recommends following inspections, as required by local authorities in platforms country of origin.

A pre-use inspection must be done before taking the platform to use for the first time and before first start-up after major repairs and alterations.

A thorough inspection and a test loading of the lift must be carried out at least once every twelve (12) months.

The platform should undergo a major inspection within ten (10) years after having been originally put into service. A major inspection includes non-destructive testing and inspection while dis-assembled.

A special inspection should be done if the platform has been exposed to exceptional circumstances which may have affected the structural integrity of critical components.

The inspections should be carried out on regular basis throughout the service life of the lift. If the lift is used under extreme conditions, intervals between the inspections shall be reduced.

The overall operating condition of the lift as well as the condition of the safety-related control devices shall be established in the regular inspections. Particular attention shall be paid to changes which affect the operational safety.

During inspections the notifications given in previous inspections, practical experience from use and information on performed repairs should be taken into account and can be implemented for better safety.

Major and special inspections shall be carried out by a competent person or competent body, who is familiar with the operation and structure of the lift. The competent person should periodically update their knowledge and be able to demonstrate their competency if so required.

A report should be made of the inspections and the reports should be kept with the unit stored in the space reserved for it.

### **NOTICE**

**Check the regulations for the inspections and the competence of the inspector with the local authorities.**

**7.2. LUBRICATION PLAN**

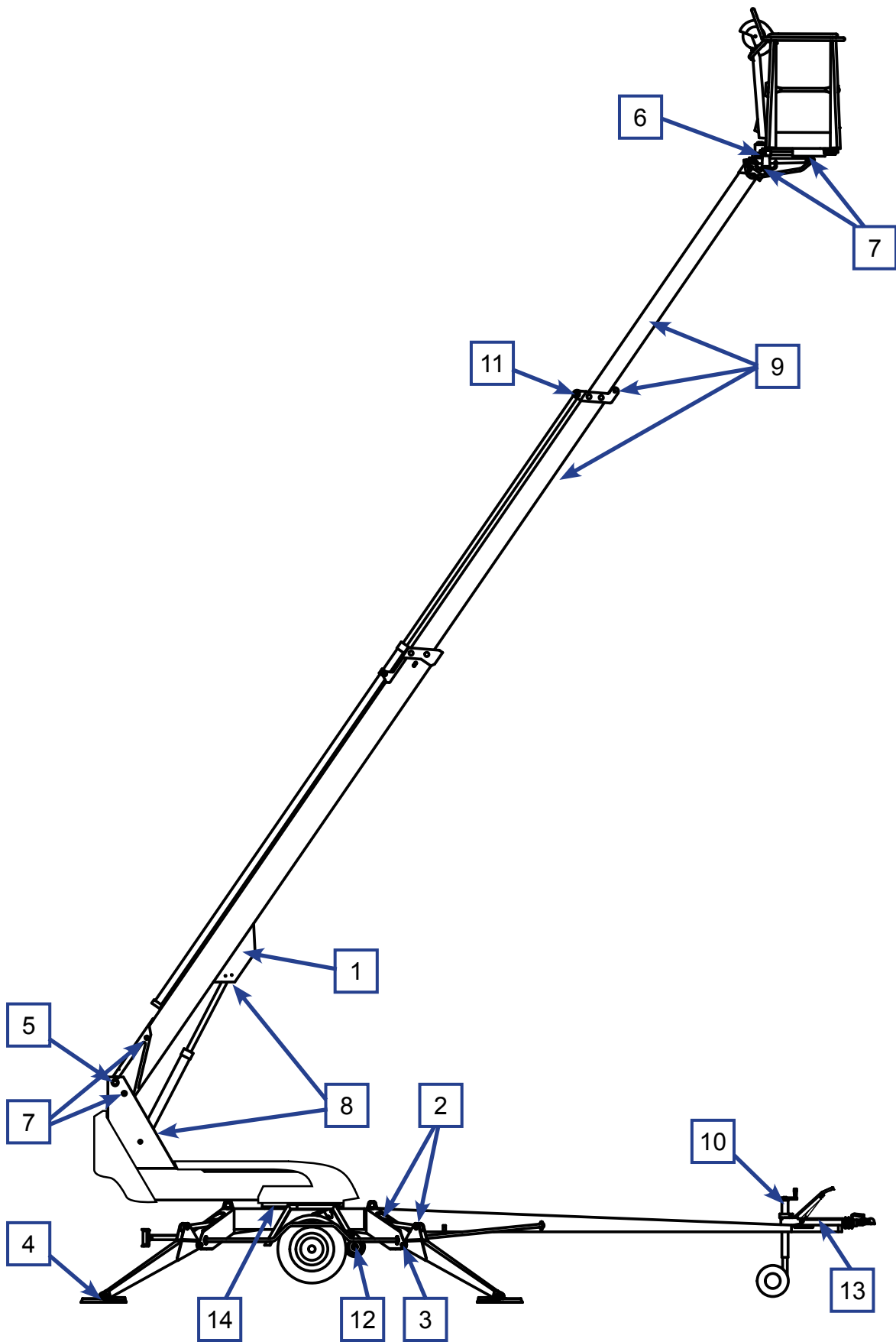

## 8. ROUTINE MAINTENANCE DURING OPERATION

The maintenance operations, that are the responsibility of the operator, are described in this chapter.

The more demanding maintenance operations that require special skills, special tools or specific measurements and adjustment values are instructed in the separate Maintenance Instructions. In such maintenance and repair cases, the operator shall contact an authorized service provider, the distributor or the manufacturer.

Make sure that all the service and maintenance procedures of the lift are performed in time and according to the given instructions.



### WARNING

Any such faults, observed during operation or periodic service, which affect the operational safety of the unit, must be repaired before the lift is used next time.

Keep the lift clean. Clean the lift especially carefully before services and inspections. Impurities may cause serious problems, for example, in the hydraulic system.

Use original spare parts and consumables. Consult the spare parts list for more detailed information about the parts.

#### **The first service after 20 hours of operation**

- change the pressure filter element
- adjust the brakes according to the instructions (see point “Wheel brakes and bearings”)
- check the wheel bolts for tightness after about 100 km of driving

**If the lift is operated under demanding conditions (in exceptionally humid or dusty environment, corrosive climate, etc.) the intervals between the oil changes and the other inspections shall be shortened to meet the prevailing conditions in order to maintain the operational safety and reliability of the lift.**

**The timely performance of the periodic servicing and the inspections is absolutely mandatory, because neglecting them may impair the operational safety of the lift.**

**The guarantee will not remain valid, if the servicing and the periodic inspections are not performed.**

## 8.1. INSTRUCTIONS FOR DAILY MAINTENANCE AND INSPECTIONS

### 8.1.1. Check the condition of chassis, the boom and the work platform

Check visually the condition of the access routes, the work platform, the platform gate and the handrails.

Check visually the condition of the boom and the frame structures.

### 8.1.2. Check the tyres and tyre pressure

Check visually that the tyres are duly inflated, and do not show any damage.

### 8.1.3. Check the lights

Check the condition of all the warning and signal lights as well as the road traffic lights of the trailer.

### 8.1.4. Check the hydraulic oil level

Check the hydraulic oil level with the platform in the transport position.

As required, top up hydraulic oil to the upper mark on the dipstick.

The hydraulic oil tank is located under a cover of the turning device as shown in the picture.

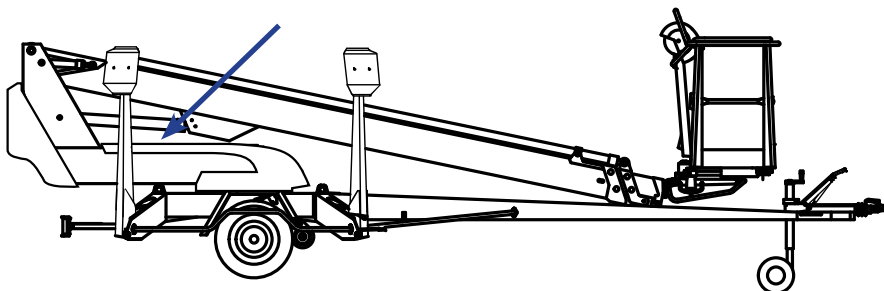

### 8.1.5. Check the hydraulic hoses, pipes and connectors

Check visually the hydraulic hoses, pipes and connections.

Make sure that there are no visible oil leaks.

Replace any externally damaged hoses and clashed pipes or fittings.

### 8.1.6. Check the operation of the safety limit switches

Test the operation of the safety limit switches that prevent the movements of the boom and the outriggers as follows:

1. The lift is in the transport position with the outriggers in the upper position, and the driving device connected.
2. Lift the boom via the controls in the chassis control centre.  
**The boom must not operate in any position of the selector switch.**
3. Lower the outriggers to the operating position of the lift
4. Using the controls in the chassis control centre, lift the boom so much that it raises from the support
5. Drive the outriggers.

**The outriggers must not operate in any position of the selector switch.**

### 8.1.7. Check the operation of the emergency descent, the emergency stop and the sound signal

Test the operation of the emergency stop, the emergency descent system and the sound signal from both the chassis control centre and the platform control centre.

- lift the boom about 1–2 metres, and extend the telescope by 1–2 metres, keeping the emergency stop button depressed – the movement shall now stop
- using the emergency descent, retract first completely the telescope, then lower the boom
- pull up the emergency stop button
- test the operation of the sound signal

### 8.1.8. Decals, stickers and signs

Check that all the signs, warning decals and pictorials on the control centres are in place, intact and clean.

If the labels have started to come off or tear apart, or if the symbols or texts are illegible, then the decals must be replaced.

Product numbers of the decals are visible on the decals or the product numbers of new decal sets can be found in the spare part list.

### 8.1.9. Instruction manuals

Check that the user manuals accompanying the lift are legible.





**BLANK**





**BLANK**



## 9. CHANGE OF OWNER

For the owner of the lift:

If you have purchased a used DINO lift from some other than the manufacturer, please post your details to the manufacturer using the form on this page, and send it to:

info@dinolift.com

This information makes it possible for us to provide you with the safety bulletins and other campaigns relevant to your machine.

Note! It is not necessary to inform about a rented machine.

Machine model: DINO \_\_\_\_\_

Serial number: \_\_\_\_\_

Previous owner: \_\_\_\_\_

Country: \_\_\_\_\_

Date of purchase: \_\_\_\_\_

Current owner: \_\_\_\_\_

Address: \_\_\_\_\_

\_\_\_\_\_

Country: \_\_\_\_\_

Contact person

Name and position in the company: \_\_\_\_\_

Telephone: \_\_\_\_\_

E-mail: \_\_\_\_\_

**NOTES**

**NOTES**